



INSTRUCTION MANUAL

Installation | Maintenance | Use | Safety

Electric Fryer



Models

FIE.20 MAX
FIE.20 MAX BIP

Model: FIE.20 MAX BIP

Image merely illustrates.

CONGRATULATIONS,

You have just purchased a IMG-BRASIL equipment, product of the highest quality, safety and efficiency.

Founded in 1989, IMG-BRASIL is a respected company as one of the best and most complete companies in the field of gastronomy equipment manufacturing.

Constant innovation and improvement of its products, using top-of-the-line raw materials, ensure superior products consumed in Brazil and in more than 25 countries worldwide.

THE RELIABILITY AND CERTAINTY OF A GOOD PRODUCT ARE IN THE NAME



IMPORTANT:

**PRODUCT FOR PROFESSIONAL USE. DO NOT USE BEFORE READING THE MANUAL CAREFULLY.
IN CASE OF QUESTIONS, PLEASE CONTACT US:**

IMG-BRASIL Indústria de Máquinas para Gastronomia Ltda.

CNPJ 11.193.347/0001-14 - CREA 131726-3

Rod. Antônio Heil – KM 23 Nº 5825 – Bairro: Limoeiro – CEP 88352-502 - Brusque – SC – Brasil

Phone/fax. +55 47 3251-5555 - Website: www.metvisa.com.br

E-mail: sac@metvisa.com.br - vendas@metvisa.com.br

TABLE OF CONTENTS

1. Safety Information	4
1.1 General Warnings.....	4
1.2 Mechanical Safety	5
1.3 Electrical Safety	6
2. Technical Features	7
2.1 Main Components.....	7
2.2 Technical Data.....	8
2.3 Supply and Disposal of Device Packaging	8
3. Installation	9
3.1 Equipment Layout.....	9
3.2. Electrical connection.....	11
3.3 Safety Measures and User Instruction	12
4. Use of the Device	12
4.1 Utility.....	12
4.2 Commands	12
4.3 Operation Procedure	13
5. Cleaning and Maintenance	15
5.1 Cleaning	15
5.2 Cleaning Procedures and Products Used	15
5.3 Maintenance and Behavior in Case of Breakdowns	17
5.4 Prolonged Interruption of Device Use	17
6. Analysis and Troubleshooting	17
6.1 Problems, possible causes and solutions	17
7. Useful life of the Device and its Components	19
8. Applicable Standards	19
9. ANNEXES	20
Electrical Schema - Models FIE.20 Max and FIE.20 BIP Max.....	20
Exploded View.....	21
Fryer Spare Parts	22



ATTENTION!

The characteristics, pictures and figures presented in this manual should be considered for information purposes. IMG BRASIL reserves the right to make such modifications as may be deemed necessary without prior notice.

1. Safety Information

1.1 General Warnings

- There are precautions that must be observed when assembling, using, maintaining and discontinuing the use of this device;
- Before performing any operation (assembly, use (use), maintenance and re-use after prolonged interruption of use of the appliance), read this manual carefully;
- The equipment must be used by trained personnel familiar with the use and safety standards described in this manual;

This device is not intended for use by persons (including children) with reduced physical, sensory or mental capacities, or people with lack of experience and knowledge, unless they have received instructions regarding the use of the device or are under the supervision of a person responsible for their safety;

- It is recommended that children be supervised to ensure that they are not playing with the equipment;
- In case of change of the personnel that will work with the equipment, the new operator must be instructed about its standards and the operation
- Operator should wear appropriate Personal Protective Equipment (PPE), such as for example: use kevlar sleeves or non-flammable fabric to avoid oil burns; wear anti-slip shoes; among others;
- The operator should always be aware of situations that may cause and avoid accident hazards (such as, for example, working on dirty floors where someone may slip and fall on the appliance);
- After reading and answering all questions, this manual should be carefully stored in an easily accessible place, known by all the people who will operate the device and made available to the people who will carry out maintenance, for eventual consultations. When in doubt, consult the manual. Do not operate the device in any way with doubts;
- In the installation, it is essential to make this manual available to the professionals who will do the same;
- Never splash water on hot oil as this may cause major accidents. In case of accident, use non-flammable material to extinguish the focus. You can even place the drip tray over the tank to muffle the focus;
- Before starting cleaning and any kind of maintenance, it is essential to disconnect the appliance from the power supply and wait for the oil to completely cool down;
- Periodically check the condition of the cables and electrical parts.



ATTENTION!

Do not perform repairs on your own. Refer to the technical service authorized by the manufacturer. Use only original parts in your device.

1.2 Mechanical Safety

- Since the appliance is designed and produced for professional use, considering its purpose/usefulness, the handling of some components (for example: frying baskets) must be carried out with care;
- Before turning on the appliance, make sure that the bulbs of the temperature and safety thermostats are in perfect condition, i.e. they must not be squashed or have any other malfunction. Faulty thermostats impair the correct functioning of the device and temperature reading, which may cause accidents;
- Never splash water on the oil as this may cause a serious accident;
- If you need to move some frying, use a spatula;
- Your appliance has a basket for disposal of fried foods;
- Avoid splashing oil on the floor as this will make the floor slippery and may cause accidents. In case of oil splashes, clean the floor.

The equipment described in this manual complies with the mechanical risk regulation. The requirements of the following standards have been met: NR-12 and INMETRO (see item 8 Applicable Standards).

Mechanical safety is achieved with:

- The cabinet that protects the entire tank (which is heated to high temperatures). This prevents burns to the operator;
- The frying basket facilitates the handling of fried foods;
- The drip tray (with sieve), to deposit the fried foods for a certain time, in order to let the oil drain and reuse it;
- The bottom protection plate, which in normal use of the device, protects the entire bottom of the tank, avoiding the risk of burns and contact with electrical components.



ATTENTION!

Whenever any item regarding the safety of the equipment (such as cleaning or maintenance) is removed, reset it and confirm that it is performing its function correctly.

1.3 Electrical Safety

- Periodically check the condition of the cables and electrical parts;
- Never splash water on your device. If the oil is hot, it could cause a serious accident and still drip onto the electrical connectors and cause electric shock;
- If the power cord is damaged, it must be replaced with a new one. The exchange must be made by the manufacturer, authorized agent or a qualified person in order to avoid risk;
- Do not operate the equipment in damp locations or wet clothing and shoes. Wear proper footwear, this will prevent electric shocks and even death;
- Support the appliance on a firm and dry surface;
- Never carry out any maintenance, adjustment or disassembly of the equipment connected to it. For such procedures, make sure that it is turned off by removing the plug from the electrical outlet;
- To adjust the operating temperature of the device, there is a button on the temperature thermostat. This button should be used to adjust the temperature according to the needs of the product to be fried (maximum 200° C), avoiding overheating of the oil. When the temperature reaches the stipulated zone, the thermostat will turn off the fryer resistance (or the two fryer resistances in the case of FIE models).20M and FIE.20M BIP) and will automatically turn off the indicator lamp. See the location of these components in the following photo;
- The appliance also has a safety thermostat, which turns the appliance off in case the temperature thermostat fails. For more information on this thermostat, check item 4.2 of this manual.

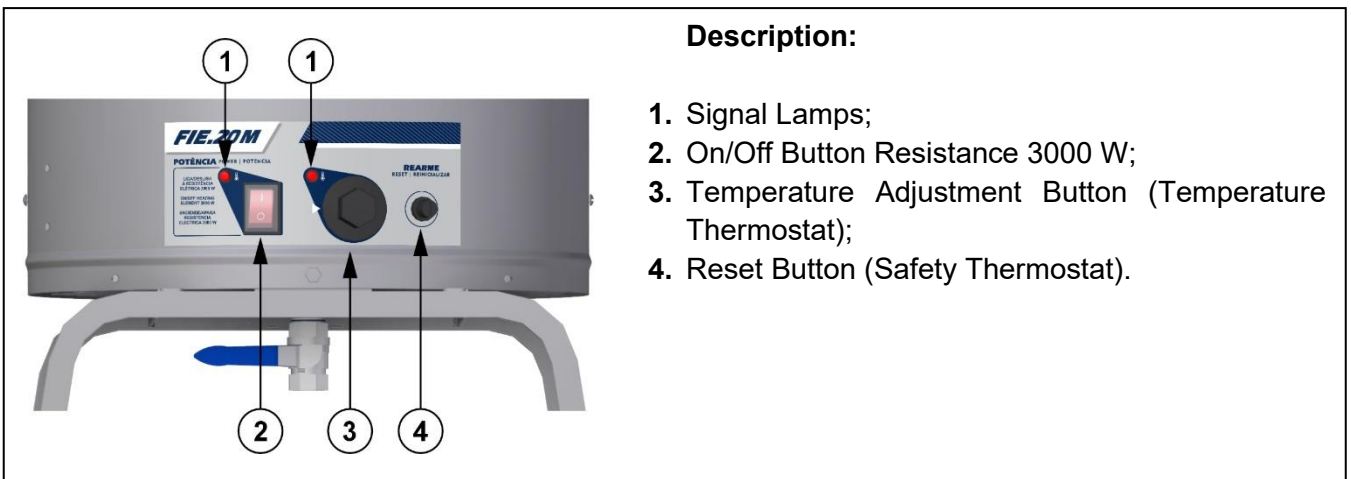

The components used for safety against electrical hazards were selected according to the standard: NR-12 (see item 8 Applicable Standards). Given the perfect insulation of all the electrical parts and the excellent resistance of all the materials used, this unit is able to carry out the works to which they are proposed.



ATTENTION!

Whenever any item regarding the safety of the equipment (such as cleaning or maintenance) is removed, reset it and confirm that it is performing its function correctly.

2. Technical Features

2.1 Main Components

For the equipment described in this manual, safety in use, cleaning, maintenance and maximum hygiene are guaranteed by the design and special design of all parts and also by using stainless steel and other materials suitable for contact with the food.

The device was built with the following features:

- Cabinet and Cup manufactured in stainless steel, which resists the attack of several corrosive agents, such as the majority of the organic acids, organic substances in general, alkalis, oxy-salts, etc..

Attention: stainless steel is attacked by sulfuric acid, and also cannot withstand hydrochloric acid, diluted sulfuric acid, chlorides and halides in general.

The following are the main components of the equipment:



Note: For the exploded drawing with spare parts list, see the annexes.

2.2 Technical Data

Model	Nominal Dimensions for Operation L x W x D (mm) *	Net Weight (kg)	Power (W)	Voltage (V)	Frequency (Hz)	Maximum temperature (°C)	Maximum Load Lot (kg)
FIE20M2205	1020x1100x465	15.4	8000	220	50/60	200	2
FIE20MBIP2205	1020x1100x465	15.6	8000	220	50/60	200	2 (1 kg per basket)

Note: The power supply network of the FIE.20 Max and FIE.20 BIP Max requires a 40 A circuit breaker.

* Dimensions considered with the drip tray and frying basket mounted.

Orientative Quantity for Fried Foods		
Coarse Salt (kg)	Water (L)	Oil (L)
1	15	23



ATTENTION!

Characteristics such as: model, serial number and voltage of the device are provided on the data label (figure below). Before installation, check that the power supply voltage of the device corresponds to that of the power grid.

The diagram shows a data label for a device. The label contains the following information:

- MODEL: FIE20XXX2205** (pointed to by 'Device Model')
- FRITADEIRA INDUSTRIAL ELÉTRICA
- Nr: XXXXXX (pointed to by 'Series Number')
- Lote: XXXXXX
- Ano Fab.: XXXX
- A barcode with the number FIE20XXX2205000001 below it.
- A table of technical specifications:

TENSÃO	CORRENTE	FREQUÊNCIA	PROTEÇÃO	PESO
220 V	XXX A	50/60 Hz	IPX4	XX kg

 (pointed to by 'Device Supply Voltage')
- Company information: IMG Brasil Indústria de Máquinas para Gastronomia Ltda., Rod. Antônio Heil - KM 23 Nº 5825 - Bairro: Limoeiro - CEP 88352-502 - Brusque - SC - Brasil, Nº Crea: 131726-3, Fone/Fax +55 47 3251-5555 - www.metvisa.com.br (pointed to by 'Other Device Features')

2.3 Supply and Disposal of Device Packaging

The equipment is packed with wood or cardboard to ensure its perfect integrity during transport and is accompanied by the following documents:

- Instruction Manual for Installation, Use, Maintenance and Safety;
- Warranty Term (for Brazilian market).

IMPORTANT

The packaging components (cardboard, wood, foam, strips, etc.) are products that can be assimilated to solid urban waste and can be disposed of without difficulty. If the equipment is installed in countries with different standards, dispose of the packaging in accordance with current regulations. Dispose of the product correctly to help protect the environment. For more information on recycling, contact your local authorities, waste disposal service or the shop where you purchased the product.

3. Installation

3.1 Equipment Layout

The connection to the mains and the arrangement for operation must be carried out by a qualified professional. Check that the voltage of the equipment matches the mains voltage.

It is essential to make this manual available to the professionals who will carry out the installation.

To facilitate transport, the appliance is packed with the dismantled easel and registration. Fixing the easel to the cabinet should be done with the screws that come with the apparatus.

Follow the instructions below for proper assembly:

1. Support the easel over a level surface;
2. Position the cabinet over the easel according to the image at the side;
3. Align cabinet holes with the easel threads;
4. Tighten the screws provided using a suitable key;
5. Finally, mount the threaded TAP into the tube below the tank. Ensure that the registration arrow is directed to the equipment to ensure correct fit.

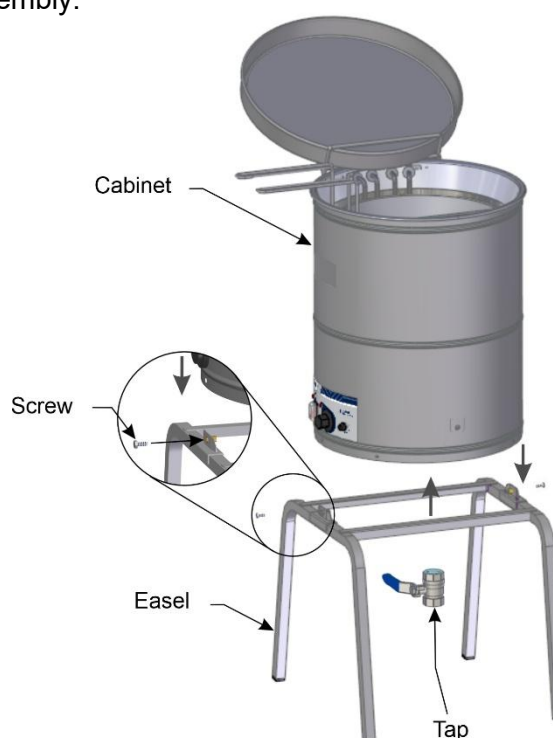

Registration Arrow Marking.

To ensure correct operation and safety, the appliance should be positioned over a sufficiently wide, level, dry and stable floor area, away from heat sources, water taps and where there is no heavy human traffic. Install your device leaving a free area on the front and top of the device, and a distance of at least 60 cm on the sides and rear, so that there is enough space for inspection, maintenance, cleaning and use.



Description

A. 60 cm minimum.

Observation: Front and Upper area of the device with free space

It is recommended that the place/establishment where this appliance is installed/used be equipped with an appropriate fire extinguisher in accordance with local regulations and requirements. The use of carbon dioxide extinguishers (also known as CO₂ carbon dioxide extinguishers) is recommended. Do not use chemical powder or water extinguishers, as these will only increase the fire. Note: In case of fire, the drip tray can even be placed on the tank to muffle the focus.



ATTENTION!

The installation and the place where the equipment will be disposed must comply with the Standards for the Prevention of Risks at Work and Safety at Work in Machinery and Equipment (Regulatory Standard NR-12).

The manufacturer shall not be liable for any direct or indirect damages caused by non-compliance with these standards and other instructions presented in this manual.

3.2. Electrical connection

For MAX FIE fryer models **20M and FIE.20M BIP** are supplied with a power cable without a plug to be connected directly to the power grid or to an industrial type plug suitable for each type of current (refer to the current for each equipment model in the table in section 2.2 Technical Data).

The unplugged power cord has three wires (Ground, Phase, and Neutral).

The neutral cable is blue in color and is identified with a sticker. It is mandatory to connect the neutral wire to the neutral of the power grid.

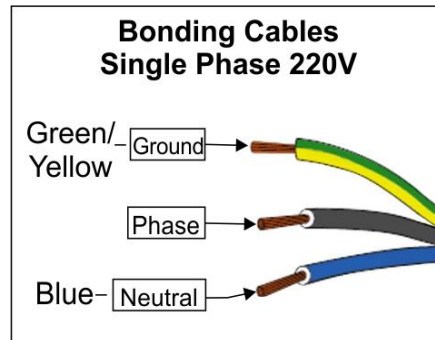

The power supply network of the FIE devices.20 and FIE.20 BIP requires a 32 A circuit breaker and for FIE models.20 and FIE.20M BIP requires a 40 A circuit breaker.

If the power cord is damaged, it must be replaced with a new one. The exchange must be made by the manufacturer, authorized agent or a qualified person in order to avoid risk.

For details of the rest of the electrical part of the appliance, refer to the electrical schema in the annexes of the manual.

All models of the devices described in this manual are single-phase and have a single voltage, that is, 220 V. If it is necessary to change the voltage in your device, contact the manufacturer or the authorized dealer.



ATTENTION!

The supply voltage of this device is 220 V (50/60 Hz), as can be seen on the voltage label attached to the supply cable or as indicated on the plate data label on the back of the device (see photo of this label in item 2.2 of this manual).

Make sure that the power grid voltage where the appliance will be installed is compatible with the voltage indicated on these labels.

IMPORTANT

The manufacturer is not responsible for any direct or indirect damages caused by non-compliance with the standards and instructions presented.

3.3 Safety Measures and User Instruction

The professional that makes the sale of the equipment should instruct the user about the correct operation of the equipment and should give you this instruction manual.

The user must be informed of the necessary safety measures and must respect them as well as all the measures described in this manual.

Your device has mechanical protections (see item 1.2 Mechanical Safety) that prevent access to moving parts and electrical components. Removal or tampering with these safety components can cause serious risks to the operator's upper limbs.

4. Use of the Device

4.1 Utility

This appliance can be used to fry various foodstuffs using a water and oil system.

4.2 Commands

Positioned in front of the appliance, the thermostat temperature control button, the signal lamp, the reset button (safety thermostat) and the 3000 W resistance on/off button are visible. Under the tank is the TAP.

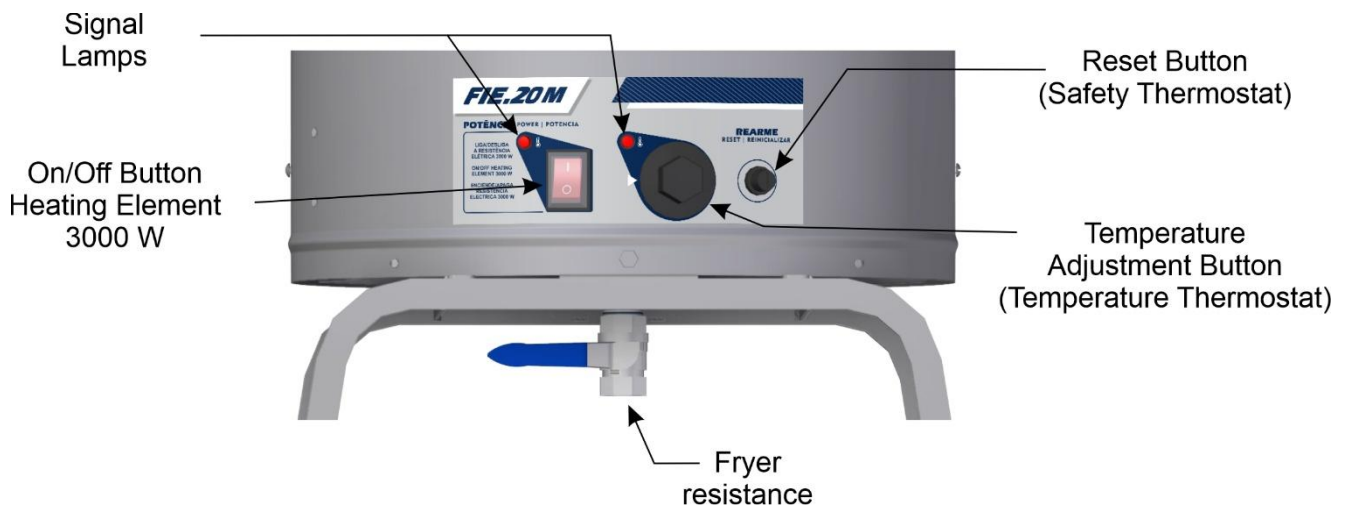

See the figure above and the description of each command:

- **TAP:** Used to drain the brine and oil in case of need to change them or in case of maintenance of the appliance.
- **Temperature Regulation Button:** used to regulate the desired temperature, according to the product to be fried (maximum temperature of 200°C). The moment the button is rotated (exits from the 0°C position) the 5000 W fryer resistance is activated.
- **Signal Lamp:** has the function of indicating when the desired temperature is reached. When the selected temperature is reached, the lamp will turn off automatically, turning off the resistance.

- **Reset Button:** is a component of the safety thermostat. It is used to reset the device, when the temperature thermostat shows any fault and/or defect. To activate the button, use some pointed object (a pen, for example).
- **3000 W Heating Element On/Off Button:** used to turn on and off the 3000 W fryer resistance. In position "1" switches on, in position "0" switches off. The 3000 W heater fryer resistance is designed to reach the desired temperature faster or to keep the temperature closer to that desired after the user inserts the food basket into the oil.



ATTENTION!

For FIE models.20M and FIE.20M BIP, the 3000 W fryer resistance can only be activated and deactivated by the on/off switch. However when the indicated temperature is reached, both fryer resistances (5000 W and 3000 W) are deactivated to maintain the temperature. If you set the temperature to 0°C on the Temperature Regulation Button, only the 5000 W fryer resistance will be turned off.



ATTENTION!

When a temperature thermostat is defective, immediately have your appliance inspected by an authorized service center for replacement. After changing the temperature thermostat, you must reset the appliance by pressing the "RESET" button, and on the other thermostat, adjust the temperature again according to the product to be fried.

4.3 Operation Procedure

Before operating the appliance, carry out a perfect cleaning, especially of the components that will come into contact with food. Clean with the appliance disconnected from the power supply. Follow the cleaning instructions in item 5 of this manual (below).

After these initial precautions, confirm that the supply voltage of the power grid is the same as that of the appliance (220 V) and that the temperature and safety thermostat bulbs are in perfect condition, i.e. they cannot be scrunched or have any other malfunction. Faulty thermostats impair the correct operation of the device and the temperature reading and may cause accidents.

The appliance may only be switched on and operated by placing the water, salt and oil elements in the tank. Never turn on your device with the tank empty or with the oil level below the indicated level so that the fryer resistance is not completely submerged, as this will cause the burning of the fryer resistance, damage to any structure and risk of fire.



ATTENTION!

There is a danger of fire if the oil level is below the "MIN. OIL " level - upper marking indicated on the inside of the tank. Always adhere to the minimum and maximum oil levels as indicated on the tank as this will prevent accidents and eliminate the risk of fryer resistance burnout.

Operation:

1. Close tank TAP;
2. Add the brine (15 liters of water and 1 kilogram of coarse salt) to the “*WATER LEVEL*” - lower marking indicated on the inside of the tank;
3. Complete with oil (23 liters) up to “*MAX. OIL*” level - upper marking indicated on the inside of the tank. Wait at least 30 minutes for the water and oil to decant, preventing the oil from boiling. Note: Recommended oil type: sunflower, soy or corn. Hydrogenated or vegetable fat and cottonseed oil is not suitable for this appliance.
4. Plug the power cord into the power grid;
5. Set the thermostat to the desired temperature range (at the maximum 200° C), where it varies according to the product to be fried. Note: when the selected temperature is reached by the thermostat, the signal lamp will turn off automatically turning off the fryer resistance;

For FIE models.20 MAX it's possible to activate the second fryer resistance (3000 W) via the on/off button in position “1” (on). This will bring the appliance up to the desired temperature faster and will help to maintain the temperature after adding the food to fry.

6. Add the product to be fried to the basket and bring it to the oil heated to the desired temperature.



ATTENTION!

Add the products to be fried slowly and gradually in the basket, thus avoiding the bubbling and spilling of oil from the tank. The bubbling will be intense when frozen products are poured.

Attention should be paid to the effect of increasing boiling in the wet foods and for very large loads.

Never splash water on hot oil as this may cause a serious accident.

Use appropriate PPE and whenever the floor is dirty, clean it.

In an emergency, remove the plug from the electrical outlet.

7. Allow enough time for the product to fry completely (until colored). After that, remove the basket and place it on top of the drip tray to allow excess oil to drip off.

After work has been completed, always clean the appliance (see instructions in item 5 of the manual), replace the appliance components in their proper place and check the brine and oil levels (complete the levels if necessary). Never operate the appliance with the oil level below the “MIN. OIL” level indicated inside the tank. After these procedures, the device will be available again to restart the operation process.

Whenever brine or oil change is necessary, disconnect the appliance from the power grid and wait for the appliance to cool completely. Once this is done, open the TAP until all the brine drains away. To change the oil, re-open the tank until all the oil in the tank has completely drained. Use appropriate containers to collect the brine and oil.

IMPORTANT

It is recommended not to use the same oil for many operating cycles. The use of old oil is dangerous, as it can have a reduced flash point and can be more conducive to boiling surges.



ATTENTION!

Do not open drain taps or other drainage devices until pressure has been reduced to about atmospheric pressure level.

According to instructions from ANVISA (National Health Surveillance Agency) some care should be taken with the oil used in frying. Here are some of them:

- *“The oil must be filtered at each end of use. During the frying of food, especially the breaded ones, which tend to release particles from its surface, remove visible residues in the oil with the aid of an appropriate utensil.”*
- *“The oil should be discarded when there is foaming and smoke during frying, intense darkening of the oil and food coloration and perception of uncharacteristic odor and taste. Remember that the smoke aspect is different from the naturally released vapor”.*
- *“The oil should not be disposed of in the public sewage system, housewives can put it in plastic bags or containers and add it to organic waste. For traders and fast foods, because they discard a significant amount, it is suggested to contact companies, agencies or entities licensed by the competent environmental agency.”*

(Source: ANVISA - Technical Report No. 11, October 5, 2004; Subject: Oils and Fats Used in Frying).

5. Cleaning and Maintenance

5.1 Cleaning

Your device has been built with first class materials, so use it correctly and you will get great satisfaction. Keep your device clean and well cared for at all times, as this will give it a much longer service life.

Change brine every 3 (three) days and the oil whenever necessary. Check the instructions, warnings and recommendations given in item 4.3 of this manual regarding brine and oil change.

5.2 Cleaning Procedures and Products Used

Your device has been built with first class materials, so use it correctly and you will get great satisfaction. Keep your device clean and well cared for at all times, as this will give it a much longer service life.

A daily cleaning of the machine must be carried out for good operation and durability.



ATTENTION!

Before cleaning the appliance, make sure that the plug is disconnected from the power grid. In addition, wait for the full cooling of the equipment.



ATTENTION!

Do not use a water jet to clean the appliance.

IMPORTANT

This equipment is not intended to be fully immersed in water for cleaning. Follow the instructions below to find out which parts can be immersed and the special care to be taken with the other parts.

Care should be taken during cleaning to eliminate the risk of electric shock and burning of electrical components of the appliance. It is advisable to:

- Never get the cabinet wet, as water may drip onto the electrical parts;
- Never splash water directly on the power cord and plug;
- When cleaning the bottom of the tank and the easel, avoid splashing water as it may wet the electrical parts.

The baskets, the drip tray and the sieves, being removable, can be immersed and washed separately with mild soap. The tank (when empty) should only be washed internally with mild soap and water, rinsing and drying it. The rest of the appliance should only be cleaned with a damp cloth as often as possible in order to prevent food residues from drying out. Never use abrasive products or sponges, as they may scratch or damage the surface of the parts.

Thoroughly clean the corners of the appliance, eliminating food residue.

Never use abrasive products or sponges and substances containing acids or chlorine to clean the metallic parts, as they may scratch or damage the surface of the parts causing corrosion points. Do not spill water on the electrical parts for cleaning, otherwise turning it on may cause electric shock or even burn the appliance.



ATTENTION!

It is very important that the cleaning products employed ensure maximum hygiene and are non-toxic.

5.3 Maintenance and Behavior in Case of Breakdowns

The operator must be instructed to perform routine inspections, making minor adjustments, the cleaning and to observe signs of breakdowns that could occur. Examples include: checking for extraneous noise; loss of power of the appliance; the non-performance by the appliance of the service to which it proposes; among others. Actions such as these are essential to ensure a longer equipment life.



ATTENTION!

When maintenance is done (even if small adjustments), always unplug the appliance from the power grid.

It is also recommended to always perform preventive maintenance, checking and adjusting gaps, cleaning the internal parts, etc. When detecting broken or malfunctioning parts, always replace using original parts.

By carrying out preventive maintenance, the inconvenience of keeping the device still when needed most is eliminated, the cost of maintenance is reduced and the risk of accidents is reduced.



ATTENTION!

Preventive maintenance requires a trained professional.

Make sure the device is disconnected from the power grid.

Whenever an item related to the safety of the device is removed (e.g. when performing maintenance), put it back in its proper place and confirm that it is performing its function correctly.

When a breakdown or non-compliance is detected, refer your device to the nearest technical assistance. See technical assistance on our website: www.metvisa.com.br

5.4 Prolonged Interruption of Device Use

When you have to leave the appliance idle for an extended period of time, disconnect it from the power grid, turn off the circuit breaker and perform a complete cleaning, including the different accessories. It is advisable to protect all parts of the appliance with white vaseline oil or suitable commercially available products. You should also protect the equipment from dust by covering it with a nylon screen or other material.

6. Analysis and Troubleshooting

6.1 Problems, possible causes and solutions

Products with IMG quality are designed with materials and components that guarantee longer life to your equipment. However, due to natural wear, improper use or lack of maintenance, the equipment may have irregularities in its operation.

In the following table, you can check possible causes and solutions:

PROBLEMS	POSSIBLE CAUSES	SOLUTIONS
Device doesn't turn on.	Lack of electricity.	Check for power on the network. Check that the power cord is plugged into a wall outlet.
	Device voltage different from network voltage.	Send the equipment to the nearest authorized service station or contact the factory.
	Safety thermostat activated.	Press reset button and switch the device on again.
		Send the equipment to the nearest authorized service station or contact the factory.
Miscellaneous electrical problems (fryer resistance, thermostats, wiring, reset button, bulbs).	Send the equipment to the nearest authorized service station or contact the factory.	
Appliance switches off in the middle of operation.	Lack of electricity.	Check for power on the network. Check that the power cord is plugged into a wall outlet.
	Miscellaneous electrical problems (fryer resistance, thermostats, wiring, reset button, bulbs).	Send the equipment to the nearest authorized service station or contact the factory.
	Safety thermostat activated.	Press reset button and switch the device on again.
		Send the equipment to the nearest authorized service station or contact the factory.
Device with oil leakage.	Badly fastened TAP, thread wear, collision.	Send the equipment to the nearest authorized service station or contact the factory.
Device with the smell of burning or smoke.	Machine voltage different from power grid voltage.	Send the equipment to the nearest authorized service station or contact the factory.
	Miscellaneous electrical problems (fryer resistance, thermostats, wiring, reset button, bulbs).	Send the equipment to the nearest authorized service station or contact the factory.
	The oil has lost the ideal characteristics for frying.	It is recommended not to use the same oil for many operating cycles. Check some ANVISA (National Health Surveillance Agency) instructions on page. 15.
Appliance takes time to fry the food.	Brine recipe (water and salt) and amount of oil different from that indicated in this manual.	Follow recipe in item 4.3 Operating Procedure (page 14).
	Miscellaneous electrical problems (fryer resistance, thermostats, wiring, reset button, bulbs).	Send the equipment to the nearest authorized service station or contact the factory.

For more information and clarifications, pcontact the nearest Authorized Technical Assistance. See technical assistance on our website: www.metvisa.com.br

7. Useful life of the Device and its Components

The life of the equipment can vary from 3 to 5 years depending on the proper use, cleaning, maintenance and quality of its components.

The following is the useful life relationship of the major components:

- 5,000 W resistor: 100,000 cycles;
- Temperature Thermostat: 100,000 cycles;
- Safety Thermostat: 100,000 cycles;
- Cables and wires: 25 years;
- Electrical terminals: 8 years.

8. Applicable Standards

The standards applied for the development of the equipment and preparation of this manual are:

- IEC 60335-1;
- IEC 60335-2-37;
- Ordinance 148 of March 28, 2022 of INMETRO;
- NR-12 - Ordinance 197 of December 2010;
- Applicable Brazilian Technical Standards (ABNT NBR).

9. ANNEXES

Electrical Schema - Models FIE.20 Max and FIE.20 BIP Max

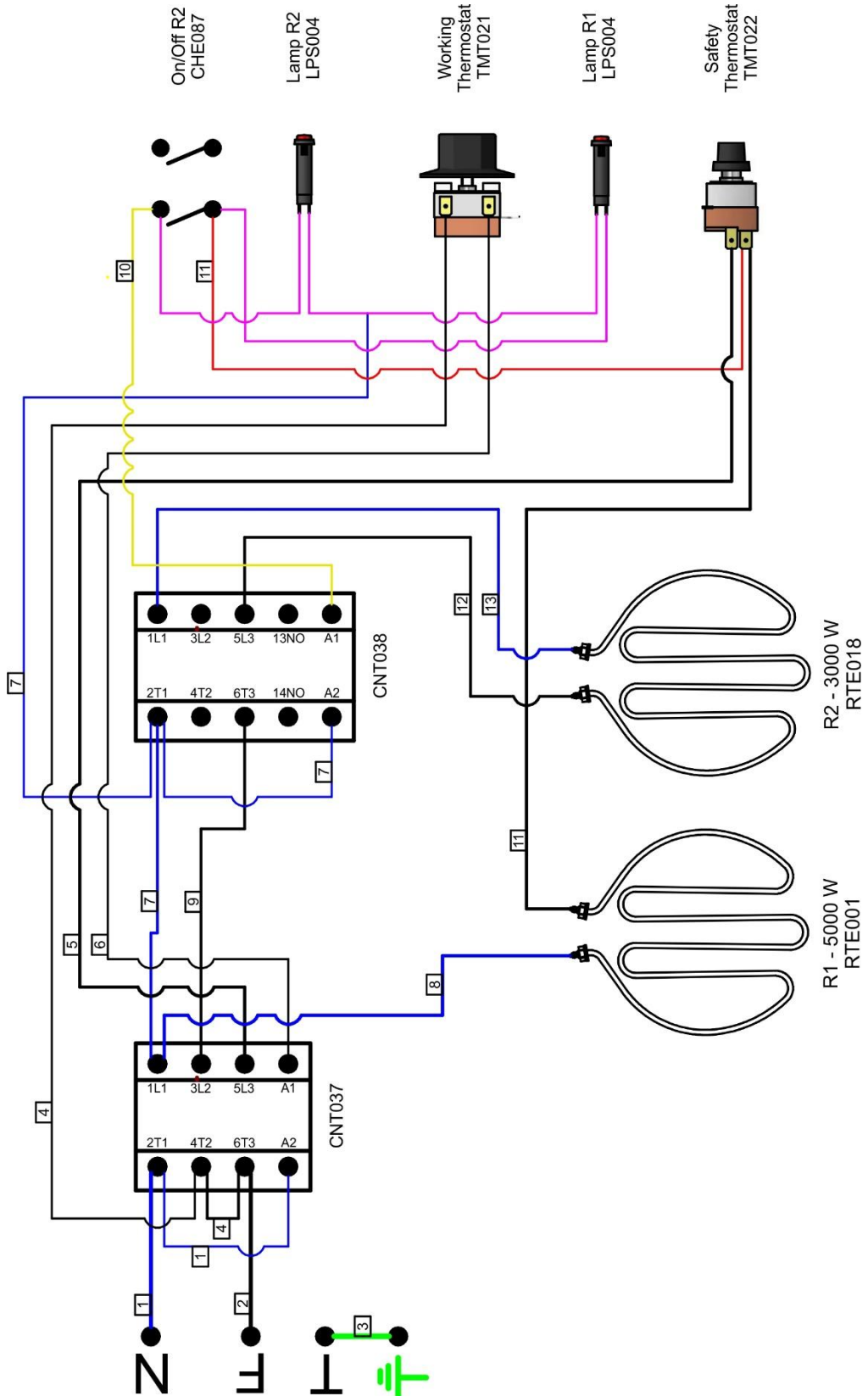

Exploded View

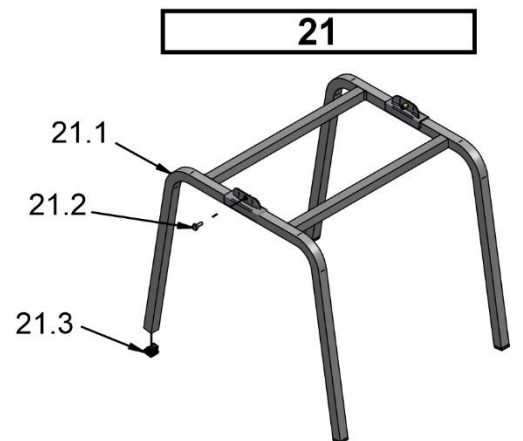
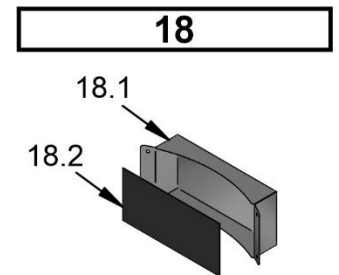
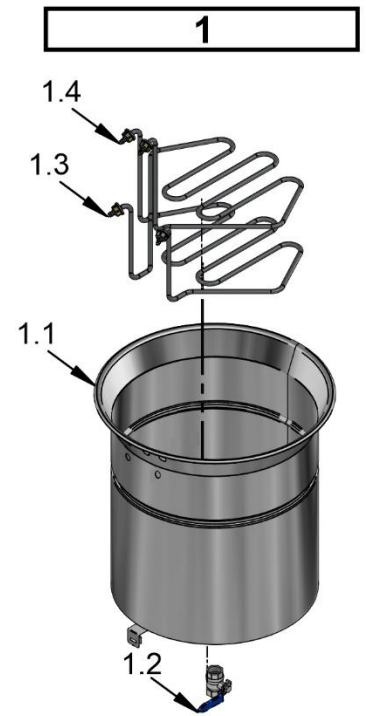
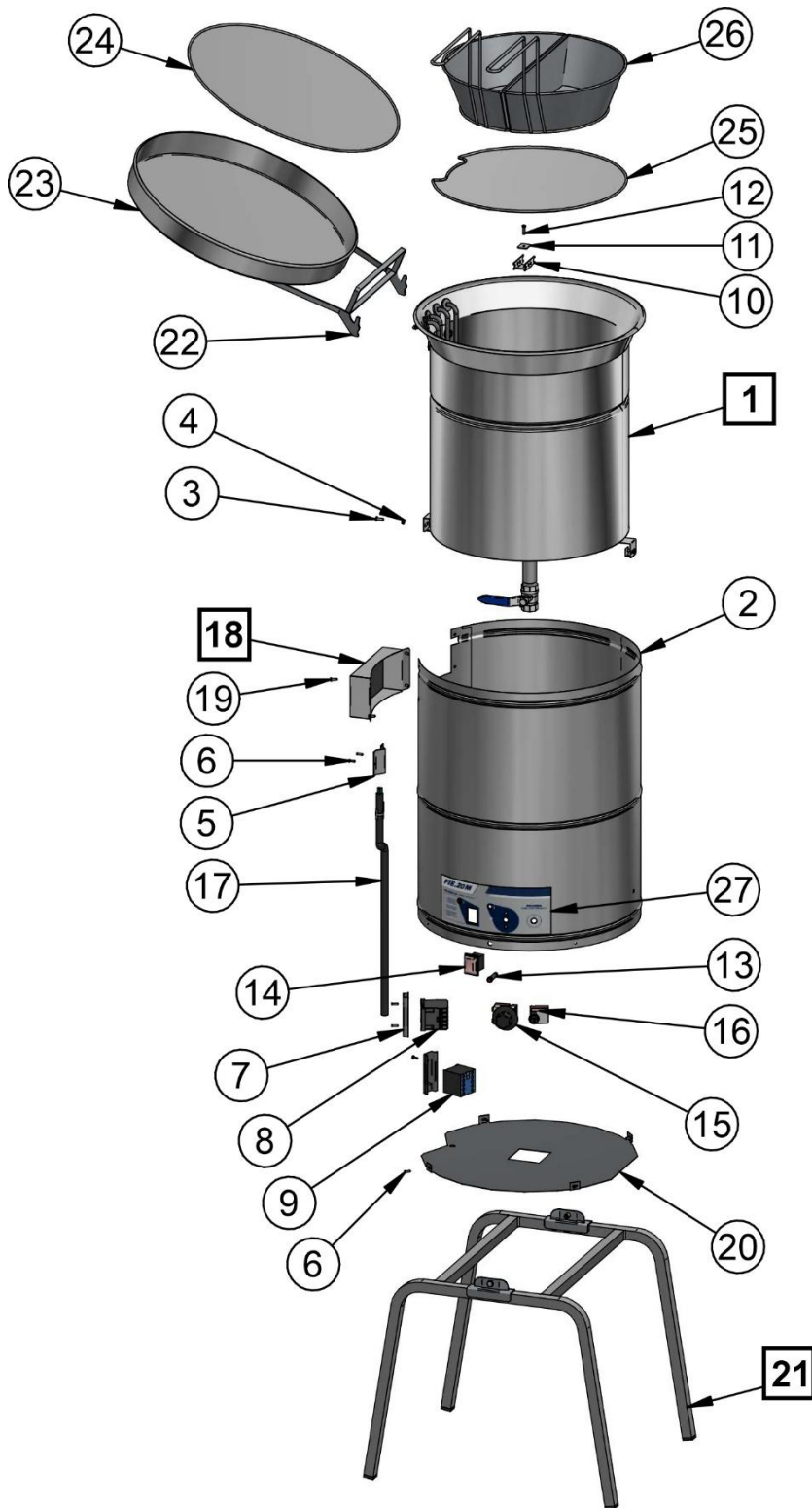

* Image merely illustrative.
Appearances can vary according
to the model.

Cable and plugs are not in the drawing,
please consider in the spare parts list.

Fryer Spare Parts

Item	Code	Description	Qty	Model
1	CJT1543	Assembled Tank	1	*
1.1	TNQ025	Stainless Steel Fryer Tank	1	*
1.2	RGT021	Valve	1	*
1.3	RTE042	5000W 220V Heating Element	1	*
1.4	RTE043	3000W 220V Heating Element	1	*
2	GAB326	Cabinet	1	*
3	PRR022	Stainless Steel Screw	2	*
4	POS006	Zinc Hex Nut	2	*
5	CRC124	Wire Guide	1	*
6	RBT002	Rivet	10	*
7	TRS051	Rail	2	*
8	CNT037	22A 190/220V 3P 50/60Hz Contactor (Mini)	1	*
9	CNT038	9A 190/220V 3P+NO 50/60Hz Contactor (Mini)	1	*
10	SBT652	Bulb Mounting Bracket	1	*
11	TRV042	Bulb Locking Plate	1	*
12	PCC012	Stainless Steel Screw	1	*
13	LPS011	Red LED Pilot Light	2	*
14	CHE087	Red Beep Switch	1	*
15	TMT021	Set Operating Thermostat 200°C 20A	1	*
16	TMT022	Safety Thermostat 230°C 20A	1	*
17	CBE269	Electrical Wiring Harness for Control and Power Supply	1	*
18	CJT1544	Cabinet Cover with Seal	1	*
18.1	CRC1760	Cabinet Cover -	1	*
18.2	VED020	Seal	1	*
19	RBT004	Rivet	4	*
20	PTC183	Bottom Protection	1	*
21	CJT909	Assembled Stand	1	*
21.1	CVT044	Welded Stand	1	*
21.2	PRS062	Hex Bolt	2	*
21.3	SPT003	Plastic Foot	4	*
22	SUE002	Sheet Slide Support	1	*
23	ECR001	Drain Tray	1	*
24	PIA002	Large Sieve Ø440mm	1	*
25	PIA022	Small Sieve Ø380mm	1	*
26	CJT099	Complete Bi-Part Basket - FIE.20 BIP	1	FIE.20M BIP
	CET001	Basket - FIE.20	1	FIE.20M
27	ADE279	Panel Sticker FIE.20 Max	1	*

* Applicable item for all models.



IMG BRASIL Gastronomy Machinery Industry Ltda.

CNPJ 11.193.347/0001-14 - CREA 131726-3
Road. Antônio Heil - KM 23 Nº 5825 - Neighborhood: Limoeiro
ZIP CODE 88352-502 - Brusque - SC - Brazil
Phone/fax. +55 47 3251-5555 - Web Site: www.metvisa.com.br
Mail: sac@metvisa.com.br - export@metvisa.com.br



Know our complete
line of products.