



INSTRUCTION MANUAL

Installation | Maintenance | Use | Safety

Bread Divider Round Model



Models

DPRC.30

DPRM.30

Image merely illustrates.

Model: DPRC.30

INDEX

1. Safety Information	3
1.1 General Warnings.....	3
2. Technical Characteristics	4
2.1 Main Components.....	4
2.2 Technical Data.....	5
3. Installation	5
3.1 Equipment Layout.....	5
4. Equipment Use	8
4.1 Utility.....	8
4.2 Manual Use.....	8
4.3 Operating Procedures.....	9
5. Cleaning and Maintenance	10
5.1 Cleaning Procedures and Products Used.....	10
5.2 Breakdown Maintenance and Procedures.....	11
6. ANEXXES	13
Exploded View Drawing.....	13
Spare Parts List.....	15



ATTENTION!

The characteristics, pictures and figures presented in this manual should be considered for information. IMG BRASIL reserves the right to make such modifications as may be deemed necessary without prior notice.

1. Safety Information

1.1 General Warnings

- Cautions / precautions must be observed when installing, using, maintaining and discontinuing use of this equipment;
- Before carrying out any operation (assembly, use, maintenance and reuse after prolonged use of the equipment), read the manual carefully;
- The equipment must be used by trained personnel familiar with the use and safety regulations described in this manual;
- This equipment is not intended for use by persons (including children) with reduced physical, sensory or mental capacities, or people with lack of experience and knowledge, unless they have received instructions regarding the use of the appliance or are under the supervision of a person responsible for their safety.
- It is recommended that children be supervised to ensure that they are not playing with the equipment;
- In case of rotation of the personnel that will work with the equipment, the new operator must be educated about the standards and the operation of the same one;
- The operator must use the **Adequate PPE** (Personal Protective Equipment). As for example: use a hair cap to prevent it from getting stuck in the moving parts of the equipment;
- The operator must always be aware of situations that can cause a risk of accidents and avoid them. For example: avoid working with loose uniform sleeves, where they can lock in moving parts, causing accidents;
- After reading and clarifying all doubts, this manual should be carefully stored in an easily accessible location, known to all persons who will operate the equipment and make it available to those who will carry out maintenance for any inquiries. Whenever any questions arise, be sure to check the manual. Do not operate the equipment in any way with doubts;
- In the installation, it is essential to make this manual available to the professionals who will do the same;
- Insert only specific products for which the equipment is intended and never put your hands, fingers or objects inside the tray, on the blades or on moving parts (rack, counterweight, etc).



ATTENTION!

Do not perform repairs on your own. Refer servicing to qualified service personnel. Only use original parts in your equipment.

2. Technical Characteristics

2.1 Main Components

For the equipment described in this manual, safety in use, cleaning, maintenance and maximum hygiene are guaranteed by the design and special project of all parts and also by using stainless steel and other materials suitable for contact with dough.

The equipment was built with the following characteristics:

- Rack and counterweight in cast iron. The handle, columns, feet and blade lock are made of carbon steel. Both parts are coated with epoxy electrostatic paint, an excellent anti-corrosion protection;
- Non-toxic plastic press (ABS), material that is easy to maintain, hygienic and resistant to corrosion;
- Tray made of aluminum. It is a lightweight material, durable and resistant to the attack of corrosive agents.
- Structure, blades and table in stainless steel, which resists the attack of various corrosive agents, such as most organic acids, organic substances in general, alkalis, oxy-salts, etc.

Note: Stainless steel is attacked by sulfuric acid, and it is also not resistant to hydrochloric acid, dilute sulfuric acid, chlorides and halides in general.

See below the main components of the equipment:

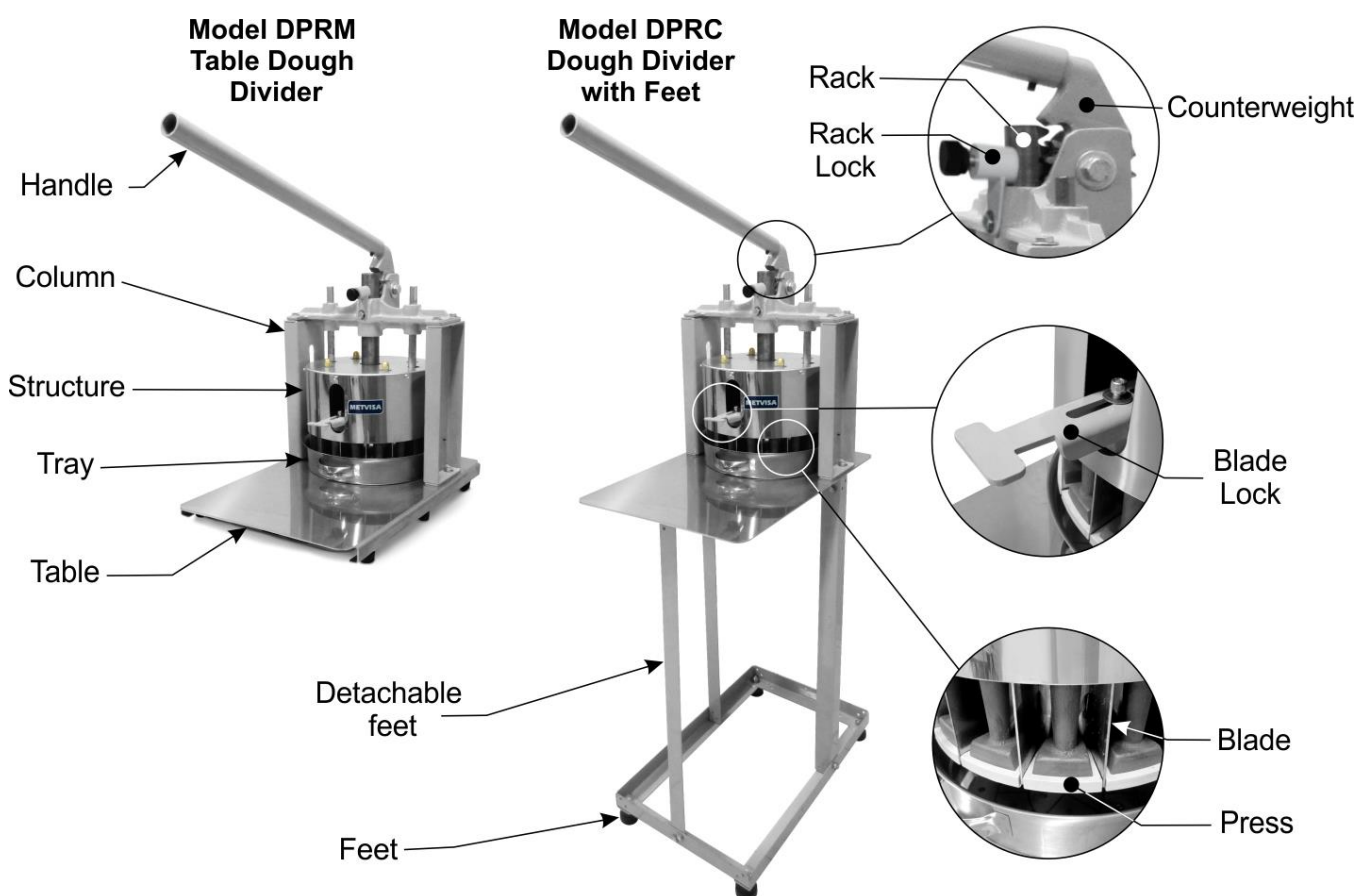

Note: For exploded drawing with spare parts list, see annexes.

Following are the mounting positions and description of the feet parts:

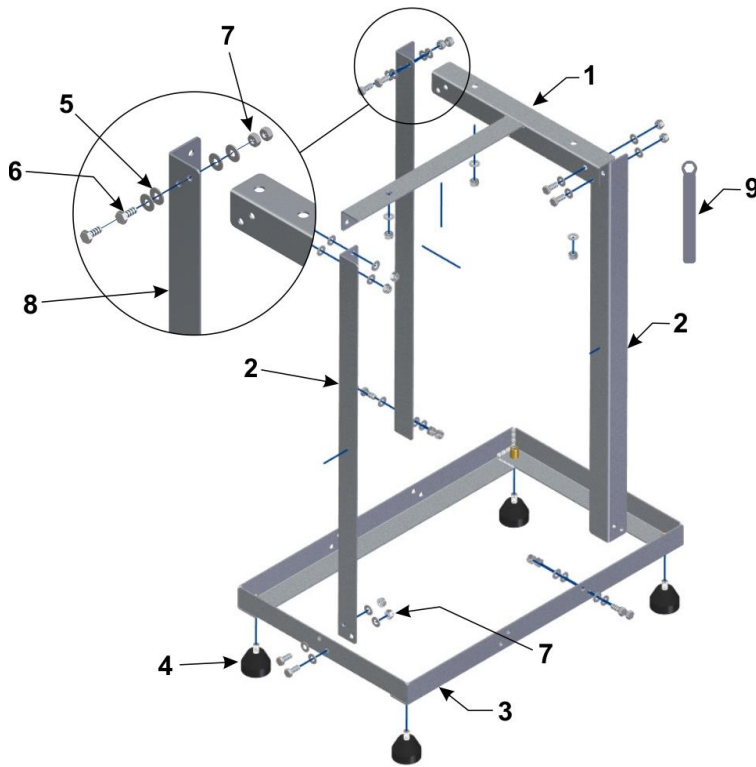

No.	Code	Description	Quant.
1	BAS091	Upper Base	01
2	CAN100	Feet	02
3	BAS092	Lower Base	01
4	PEP028	Rubber Foot	04
5	ARL007	Flat Washer 5/16"	27
6	PRS336	Hexagonal Screw M8	12
7	POS153	Hexagonal Nut M8	15
8	CAN138	Side Structure	01
9	FRG919	Star Wrench M8	02

After assembling the feet, the tie rods, located at the bottom of the equipment table, must be fitted onto the feet and fixed using the washers (M8 - Code ARL007) and nuts (M8 - Code POS153) as shown in the image below.

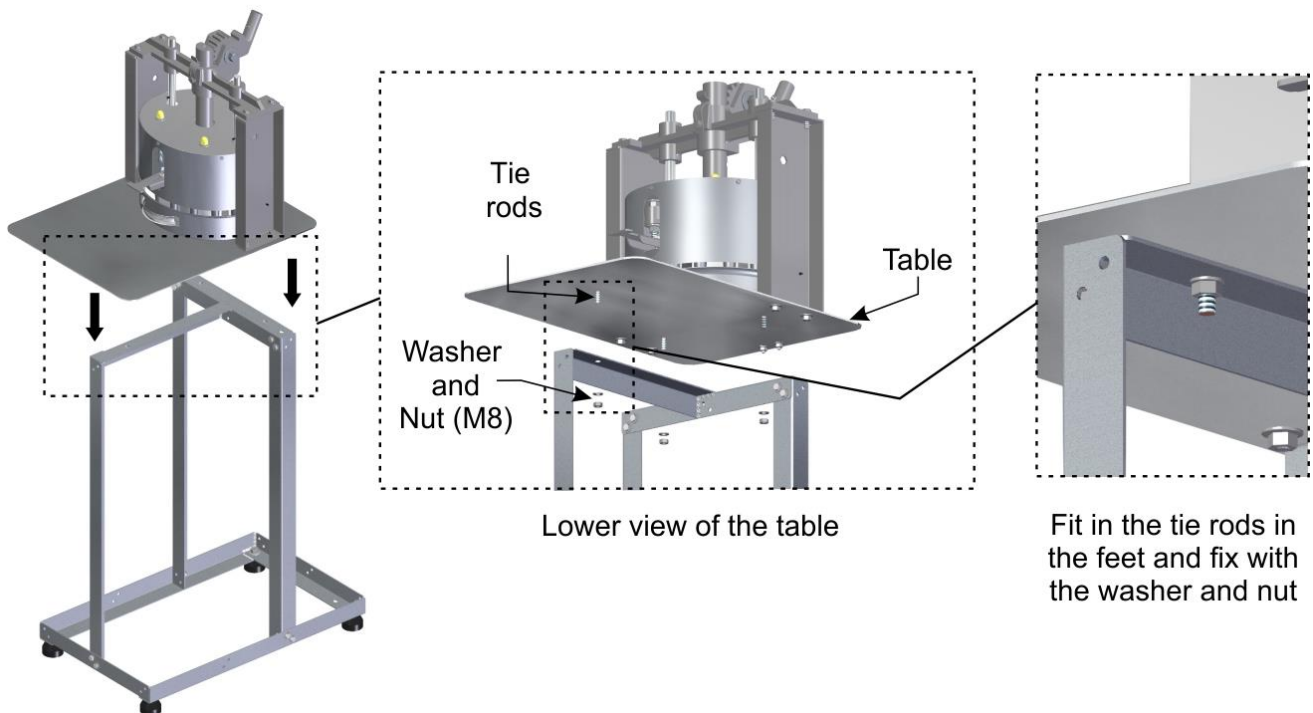

To mount the handle (image below), fit the side of the handle with the fixing hole in the counterweight. Fix the handle with the screw (Allen screw s/c 5/16" - Code PRN002) that comes with the equipment.

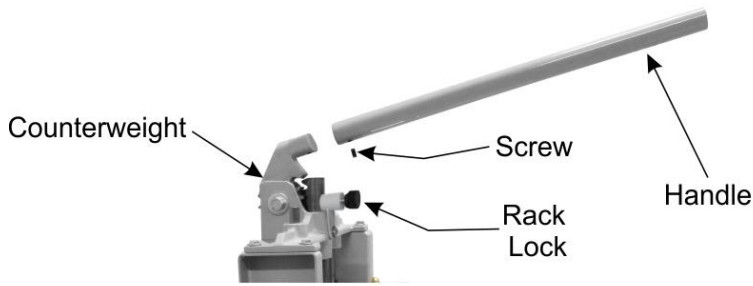

Dismantled Handle

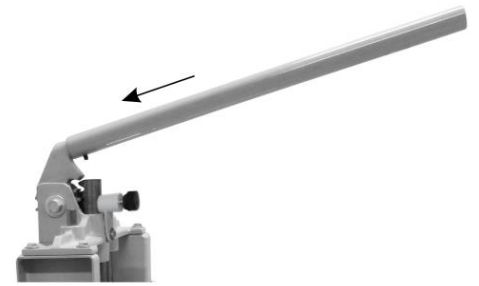

Fixed Handle

If the equipment (model DPRC.30) is not secure, it may not have been assembled correctly. In this case, repeat the operation and if unsuccessful, contact technical assistance.

To ensure correct operation and safety, the equipment must be positioned in an airy environment and on a sufficiently large, well-leveled, dry and stable support surface, away from sources of heat and water taps, and in a place where there is no heavy traffic of people. Install your equipment leaving a distance of at least 50 cm around it.

The DPRC.30 model (with feet) can be supported directly on the floor, while the DPRM.30 (table model) must be installed on a bench with an average height of 80 cm and reserve an area above the bench with at least 1.20 m high, so that it has enough space for inspection, maintenance, cleaning and use.

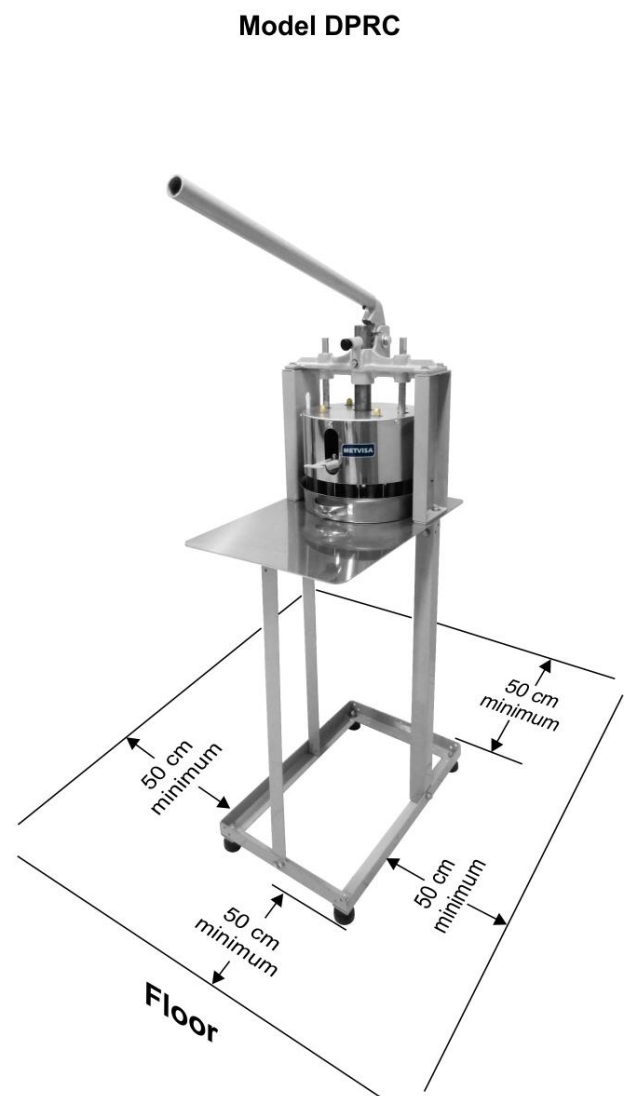
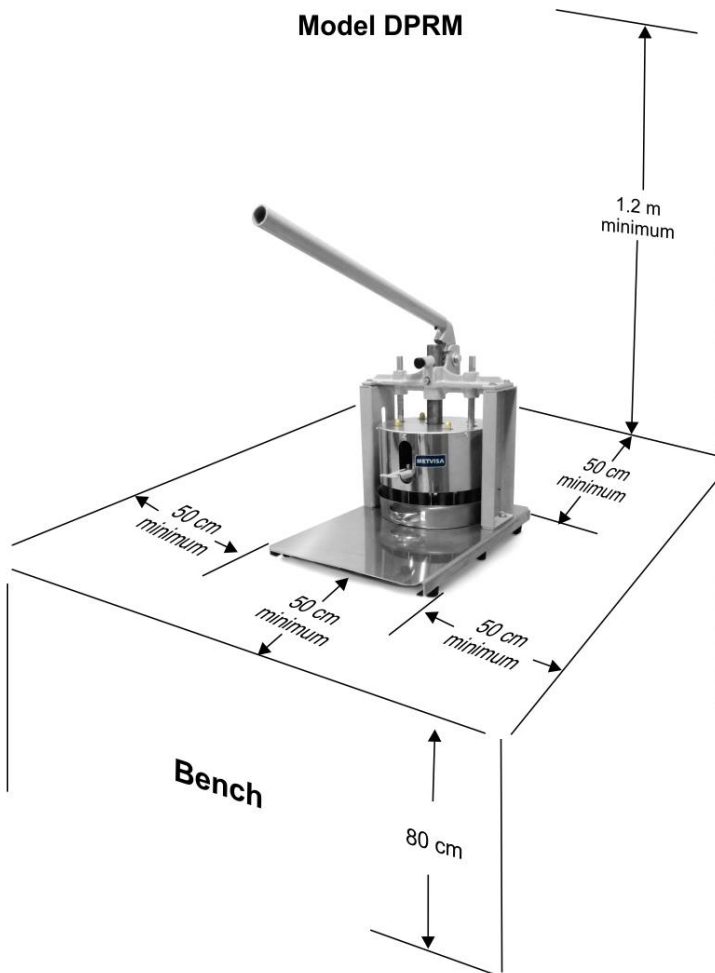



ATTENTION!

The installation and the place where the equipment will be placed must be in accordance with the Rules for the Prevention of Risks at Work and Safety at Work in Machines and Equipment (Regulatory Norm in each country).

The manufacturer does not take responsibility for possible direct or indirect damage caused by failure to comply with said standards and other instructions presented in this manual.

4. Equipment Use

4.1 Utility

Equipment used exclusively for dividing bread dough into equal parts.

4.2 Manual Use

The equipment consists of a handle, rack lock and blade lock, located on the front of the equipment.

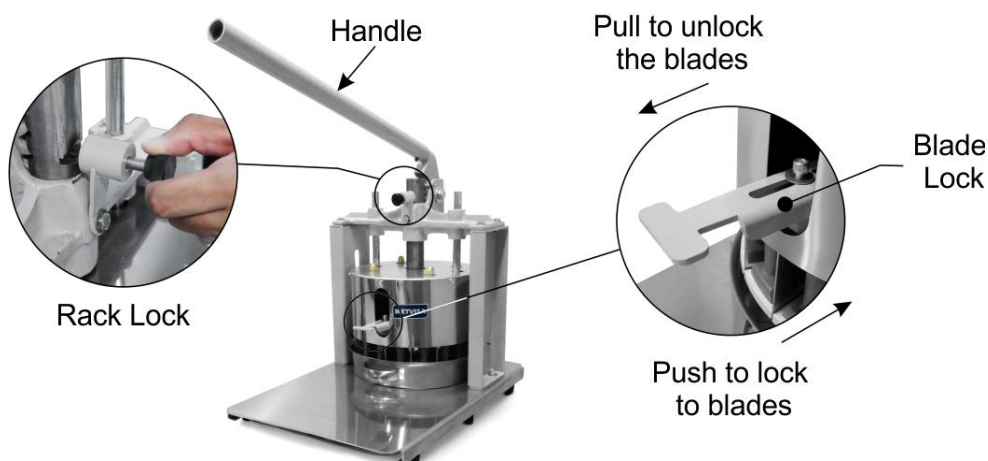

See description of each command below:

- **Handle** – used to move the press base where the blades are located.
- **Rack Lock** – to lock the rack, simply push the handle up to the end of the stroke. The lock is intended to prevent the handle from dropping suddenly. To unlock, hold the handle with one hand and pull the handle releasing the handle for movement.
- **Blade Lock** – locks and unlocks the blades. When pushing the lock, the blades will be unable to move. Keep the lock in this position to press the dough. To unlock the blades, pull the lock. In this way it is possible to divide the dough.

4.3 Operating Procedures

Before operating your equipment, clean the components that will come into contact with the dough (tray, table, blades, etc.). Follow the cleaning instructions in item 5 of this manual.

• **Operation:** Before using the equipment, make sure that all the parts are properly fitted (feet and handle in DPRC.30 models) and check the correct arrangement of the equipment as instructed in item 3.1 (Equipment Layout).

Follow the equipment operation procedure below:

1. First, lift the handle to the end of its stroke and make sure it has been locked with the rack lock;
2. Evenly distribute the already weighed dough on the tray (see capacity table in item 2.2 Technical Data);
3. Check that the blades are locked by pushing the blade lock inwards;
4. Place the tray under the press base until it hits the back of the tray;

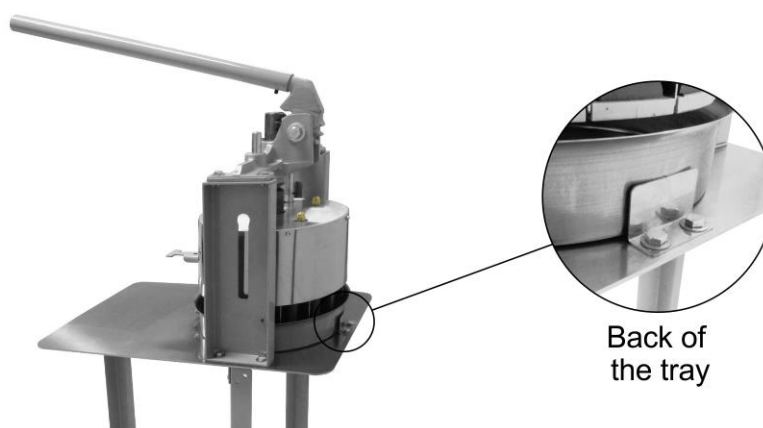

5. Lower the handle to press the dough and then raise it;
6. Pull the blade lock to unlock the blades;
7. Lower the handle to divide the dough;
8. Raise the handle to the end of its stroke and make sure it is locked with the rack lock. Remove the tray and place the dough on a bench to separate the pieces. After that, forward the dough to the IMG bread molder.



Remove the tray with the divided dough

9. After the end of the equipment operation, perform the cleaning according to the instructions in item 5 (Cleaning and Maintenance).



ATTENTION!

If you notice that the equipment cannot make the cut, check that the blades are unlocked and that the amount of dough is in accordance with the capacity of each equipment (see table in item 2.2).

Never use instruments that are not part of the equipment to assist in the operation.

Do not lower the handle with the tray out of position and do not insert non-dough products into the tray.

Failure to comply with these guidelines will be considered an unsafe act and abusive use of the equipment.

IMPORTANT

The operator must use the appropriate PPE (personal protective equipment). For example: wearing hair caps to prevent them from getting stuck in the moving parts of the equipment and appropriate gloves that, in addition to ensuring hygiene in handling the dough, protect the operator during food processing.

IMPORTANT

The manufacturer does not take responsibility for possible direct or indirect damage caused by failure to comply with said standards and other instructions presented in this manual.

5. Cleaning and Maintenance

5.1 Cleaning Procedures and Products Used

Your equipment was built with first-line materials, so use it properly and you will obtain great satisfaction. Always keep your equipment clean and well-cared for, which will make it much more durable.

Daily cleaning of the equipment must be carried out for good operation and durability. Preventing the accumulation of bacteria which can cause contamination in food.



ATTENTION!

Do not use water jet to clean the equipment.

IMPORTANT

This equipment is not intended to be immersed in water for cleaning. Follow the instructions below to learn the parts that can be immersed and what special care is taken with the other parts.

The detachable part (only the tray) must be removed from the equipment and washed with hot water and neutral soap. Clean the corners well, removing residue from the dough.

The rest of the equipment must be cleaned as many times as possible, to prevent dough residues from drying and sticking to the parts. For cleaning, dilute the soap or neutral detergent in warm water and apply with a soft cloth. With a cloth dampened with water, rinse and then dry the parts with a soft, dry cloth.

Never use abrasive products or sponges for cleaning, as they can scratch or damage the surface of the parts.



ATTENTION!

Take care when cleaning the blades as they are sharp. Use only a damp cloth, handling the blades with care, otherwise accidents may occur. The same precautions apply to any other sharp component of the equipment. It is extremely important that the products used for cleaning ensure maximum hygiene and that they are non-toxic.

IMPORTANTE

The manufacturer does not take responsibility for possible direct or indirect damage caused by failure to comply with said standards and other instructions presented in this manual.

5.2 Breakdown Maintenance and Procedures

The operator must be instructed to carry out routine inspections, making small adjustments, cleaning and observing signs of breakdowns that may occur. Examples include: checking for strange noises; loose parts; lack of lubrication of counterweight, rack and guides; the non-execution by the equipment to the service to which it is proposed; among others. Actions like these are indispensable to guarantee a longer equipment life.

It is recommended that each 6 months be made preventive maintenance, checking and adjusting the loose, cleaning the internal parts, and others. Detecting broke parts or without the correct functionality the worker needs to exchange the parts, always using original parts only.



ATTENTION!

Never let your equipment work without lubrication, as it will cause damage to your equipment.

It is recommended to lubricate the parts every 6 months of use or 800 hours worked.

This equipment uses Food Grade Non-Toxic White Grease on the rack, counterweight and press base guides (rods).

By carrying out preventive maintenance, the inconvenience of having the equipment stopped when it is most needed is eliminated, the cost of maintenance is reduced and the risk of accidents is reduced.



ATTENTION!

The preventive maintenance must be made by a capacity person.

Always that some item referred to safety be removed from the equipment (for example, for cleaning or maintenance), replace it in place and confirm that it is performing its function correctly.

Detecting broke parts or without the correct functionality, please contact the nearest authorized service center.

6. ANEXXES

Exploded View Drawing

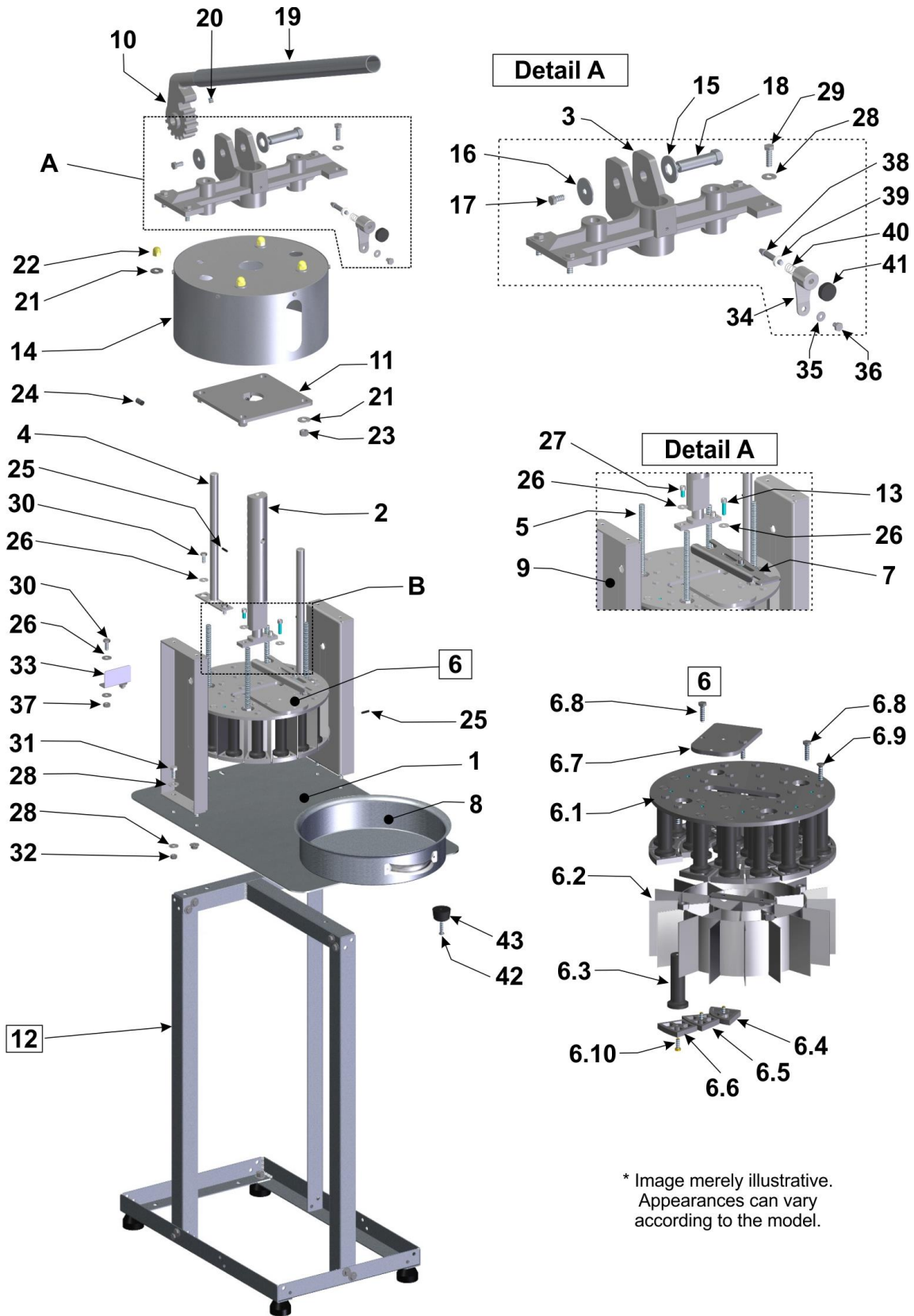

* Image merely illustrative.
Appearances can vary
according to the model.

Exploded View Drawing – CVT033 (Feet)

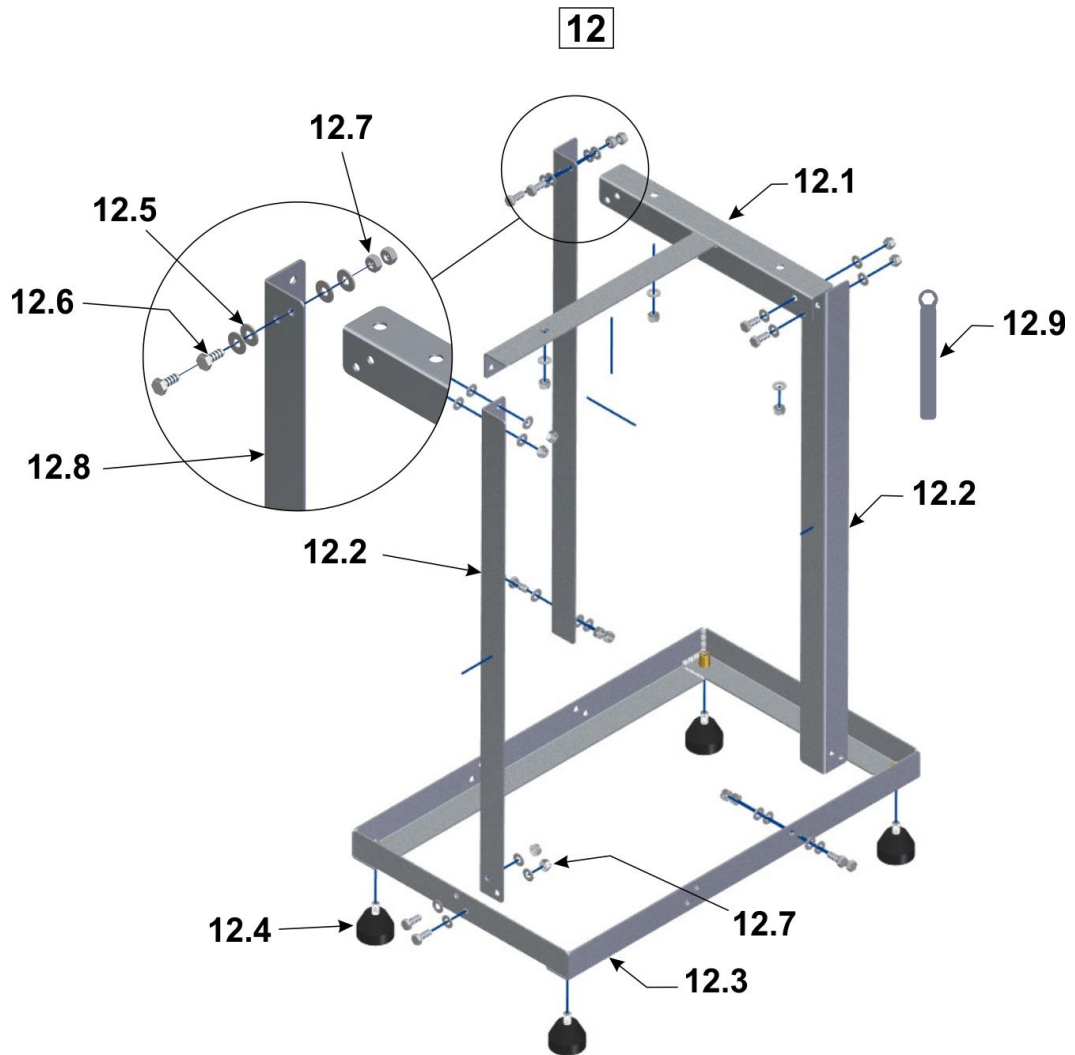

Spare Parts List

Position	Code	Description	Quantit	Model
1	MSA009	Welded Table	01	DPRC.30
	MSA011	Welded Table	01	DPRM.30
2	CRM001	Rack	01	*
3	MAC051	Rack Bearing	01	*
4	CJT674	Welded Press Base Guide	02	*
5	TRT014	Rod	04	*
6	BAS137	Mounted Press Base	01	*
6.1	BAS136	Press Base Plate	01	*
6.2	CJT116	Blade	01	*
6.3	HAT062	Plastic Presser Stick Rod	30	*
6.4	TCM006	Plastic Presser 65 mm	04	*
6.5	TCM007	Plastic Presser 53 mm	10	*
6.6	TCM008	Plastic Presser 50 mm	16	*
6.7	SBT345	Press Base Shim	01	*
6.8	PRS004	Hex Screw	21	*
6.9	PRC032	Flat Machine Screw	11	*
6.10	PCC001	Cylindrical Machine Screw	30	*
7	TRV025	Blade Lock	01	*
8	BDJ007	Welded Tray	01	*
9	ETR092	Column	02	*
10	ETR091	Counterweight	01	*
11	SBT517	Blade Support	01	*
12	CVT033	Complete Feet - DPC.30	01	DPRC.30
12.1	BAS091	Upper Base	01	DPRC.30
12.2	CAN100	Feet	02	DPRC.30
12.3	BAS092	Lower Base	01	DPRC.30
12.4	PEP028	Rubber Foot	04	DPRC.30
12.5	ARL007	Flat Washer 5/16"	27	DPRC.30
12.6	PRS336	Hex Screw M8	12	DPRC.30
12.7	POS153	Hexagon Nut M8	15	DPRC.30
12.8	CAN138	Side Column	01	DPRC.30
12.9	FRG919	Star Wrench M8	02	DPRC.30
13	PRT004	Allen Screw with Head	02	*
14	CJT117	Structure	01	*
15	ARL009	Flat Washer	01	*
16	ARE001	Tin Flat Washer	01	*
17	PRS008	Hex Screw	01	*
18	EIX015	Counterweight Axis	01	*
19	HAT010	Handle	01	*
20	PRN002	Allen Screw	01	*
21	ARL002	Flat Washer	08	*
22	POC015	Stainless Hat Nut	04	*
23	POS003	Hexagon Nut	04	*
24	PRN001	Allen Screw S/C	02	*
25	PNL006	Elastic Pin	04	*
26	ARL004	Flat Washer	12	*
27	PRT006	Allen Screw with Head	02	*
28	ARL003	Flat Washer	12	*
29	PRS006	Hex Screw	04	*
30	PRS010	Hex Screw	06	*
31	PRS007	Hex Screw	04	*
32	POS004	Hexagon Nut	04	*
33	CRC031	Back of the Tray	01	*
34	SBT165	Welded Lock Support	01	*
35	ARL005	Flat Washer	01	*
36	PRS014	Hex Screw	01	*

*Item applied to all models of feet bread divisors.

Spare Parts List

Position	Code	Description	Quantit	Model
37	POS005	Hexagon Nut	02	*
38	EIX161	Lock Shaft	01	*
39	BGT040	Lock Shaft Bushing	01	*
40	MOL024	Spring	01	*
41	MNL011	Internal Thread Handle	01	*
42	PRA004	Drilling Hex Screw	06	DPRM.30
43	PEP004	Rubber Foot	06	DPRM.30

* Item applied to all models of feet bread divisors.

IMG BRASIL PRODUCT MANUFACTURER

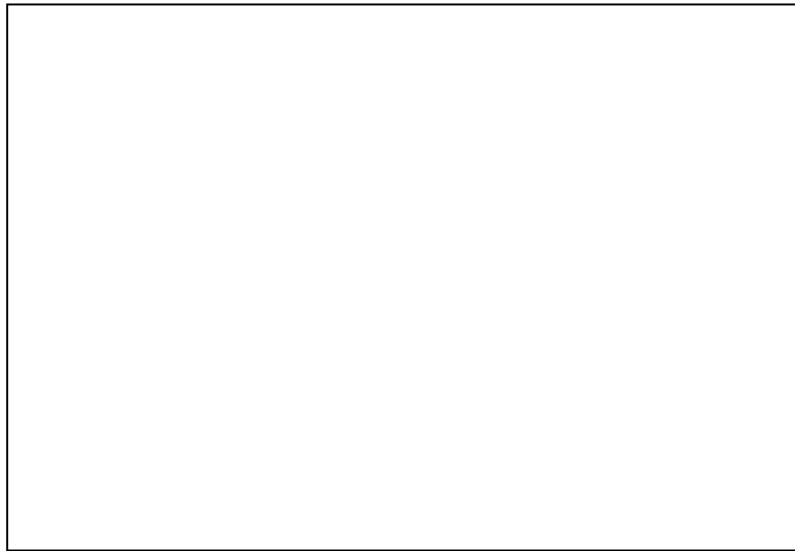

IMG BRASIL Gastronomy Machinery Industry Ltda.

CNPJ 11.193.347/0001-14 - CREA 131726-3

Road. Antônio Heil - KM 23 N° 5825 - Neighborhood: Limoeiro

ZIP CODE 88352-502 - Brusque - SC - Brazil

Phone/fax. +55 47 3251-5555 - Web Site: www.metvisa.com.br

Mail: sac@metvisa.com.br - export@metvisa.com.br



Know our complete
line of products.