



INSTRUCTION MANUAL

Installation | Maintenance | Use | Safety

Triple Buffet Server Warmer



Model

MGT

Image merely illustrates.

CONGRATULATIONS,

You have just purchased a IMG-BRASIL equipment, product of the highest quality, safety and efficiency.

Founded in 1989, IMG-BRASIL is a respected company as one of the best and most complete companies in the field of gastronomy equipment manufacturing.

Constant innovation and improvement of its products, using top-of-line raw materials, ensure superior products consumed in Brazil and in more than 25 countries worldwide.

THE RELIABILITY AND CERTAINTY OF A GOOD PRODUCT ARE IN THE NAME

IMG BRASIL PRODUCT MANUFACTURER



IMPORTANT:

**PRODUCT FOR PROFESSIONAL USE. DO NOT USE BEFORE READING THE MANUAL CAREFULLY.
IN CASE OF QUESTIONS, PLEASE CONTACT US::**

IMG-BRASIL Gastronomy Machinery Industry Ltda.

CNPJ 11.193.347/0001-14 - CREA 131726-3

Road. Antônio Heil – KM 23 Nº 5825 – Neighborhood: Limoeiro –

ZIP CODE 88352-502 - Brusque – SC – Brasil

Phone/fax. +55 47 3251-5555 - Site: www.metvisa.com.br

INDEX

1. Safety Information	4
1.1 General Warnings.....	4
1.2 Mechanical Safety	5
2. Technical Characteristics	5
2.1 Main Components.....	5
2.2 Technical Data.....	6
2.3 Supply and Disposal of Equipment Packaging.....	7
3. Installation	7
3.1 Equipment Layout.....	7
3.2 LPG Gas Installation - Recommendations and Care.....	8
3.3 Safety Procedures and User Instruction.....	10
4. Equipment Use	10
4.1 Utility.....	10
4.2 Commands	10
4.3 Operating Procedures.....	10
5. Cleaning and Maintenance	13
5.1 Cleaning Procedures and Products Used	13
5.2 Maintenance and Procedures in Case of Breakdowns	14
5.3 Prolonged Interruption in the Use of the Equipment.....	15
6. Analysis and Troubleshooting	15
6.1 Problems, possible causes and solutions	15
7. ANNEXES	17
Exploded View Drawing.....	17
Spare Parts	19



ATTENTION!

The characteristics, pictures and figures presented in this manual should be considered for information. IMG BRASIL reserves the right to make such modifications as may be deemed necessary without prior notice.

1. Safety Information

1.1 General Warnings

- Cautions / precautions must be observed when installing, using, maintaining and discontinuing use of this equipment;
- Before carrying out any operation (assembly, use, maintenance and reuse after prolonged use of the equipment), read the manual carefully;
- The equipment must be used by trained personnel familiar with the use and safety regulations described in this manual;
- This equipment is not intended for use by persons (including children) with reduced physical, sensory or mental capacities, or people with lack of experience and knowledge, unless they have received instructions regarding the use of the equipment or are under the supervision of a person responsible for their safety.
- It is recommended that children be supervised to ensure that they are not playing with the equipment;
- In case of rotation of the personnel that will work with the equipment, the new operator must be educated about the standards and the operation of the same one;
- The operator must use the **Adequate PPE** (Personal Protective Equipment). As for example: use appropriated gloves to protect the hand from burning by the hot tank;
- The operator must always be aware of situations that can cause a risk of accidents and avoid them. For example: turn on the gas regulator button without lighting the burner, spreading the gas in the environment causing poisoning, fire and explosion risks;
- After reading and clarifying all doubts, this manual should be carefully stored in an easily accessible location, known to all persons who will operate the equipment and make it available to those who will carry out maintenance for any inquiries. Whenever any questions arise, be sure to check the manual. Do not operate the equipment in any way with doubts;
- In the installation, it is essential to make this manual available to the professionals who will do the same;
- Do not install the equipment near flammable materials;
- Before starting cleaning and any type of maintenance, it is essential that the equipment is at room temperature, with the burners off and the gas pressure regulator closed;
- Periodically check the condition of the hose and the entire gas installation part as well as the internal and external part of the equipment (burners, collecting drawer, gas regulating buttons, etc.).



ATTENTION!

Do not perform repairs on your own. Refer servicing to qualified service personnel. Only use original parts in your equipment.

1.2 Mechanical Safety

- As the equipment is designed and produced for professional use, considering its purpose/utility, the handling of some components (for example: burner drawer) must be carried out with care;
- Before operating the equipment, make sure that the gas installation is free of leaks. Check for gas leaks using soap suds only.
- Insert only specific products into the tanks for which the equipment is intended and never place your hands or inflammable products, close to or directly on the heated tank or the burners.
- When cleaning the equipment, be very careful. Turn off the burner and close the gas pressure regulator (gas register). Then wait for the oil to cool completely. Never put your hands or cleaning products in the heated tank. For further information on cleaning the equipment, follow the instructions in item 5 of this manual.
- Avoid splashing food on the floor, as it will make the floor slippery, which may cause accidents. In case of sauce spills, clean the floor immediately.

The equipment described in this manual complies with the regulation against mechanical risk. Security is achieved with:

1. **Structure**, fixed, preventing inappropriate access to internal parts, such as a set of burners.
2. **Burner Drawer**, that facilitates and assures the user, to light and to visualize that all the burners are lit, avoiding gas leakage;
3. **Burner Protection** reduces heat at the front of the equipment. Avoiding overheating of the Gas Regulator buttons.

To view the parts described above, see the image in item 2.1 (Main Components – page 6) of this manual.



ATTENTION!

Always that some item referred to safety be removed from the equipment (for example, for cleaning or maintenance), replace it in place and confirm that it is performing its function correctly.

2. Technical Characteristics

2.1 Main Components

For the equipment described in this manual, safety in use, cleaning, maintenance and maximum hygiene are guaranteed by the design and special design of all parts and also by using stainless steel and other materials suitable for contact with food.

The equipment was built with the following characteristics:

- Structure made of stainless steel, which has superior corrosion resistance than other steels. It is a material resistant to the attack of several corrosive agents;
- Burner Drawer, where the Front Protection is in stainless steel, leaving the equipment with a modern design and facilitating cleaning, in addition to giving the equipment a longer useful life. Carbon steel burners with high temperature paint and the burner protection made of galvanized steel. Both materials have excellent anti-corrosion protection that gives greater durability to the part;
- Tanks and lids made of 304 stainless steel, which resists the attack of various corrosive agents, such as most organic acids, organic substances in general, alkalis, oxy-salts, etc.

Attention: 304 stainless steel is attacked by sulfuric acid, and also does not resist hydrochloric acid, diluted sulfuric acid, chlorides and halides in general.

See below the main components of the equipment:

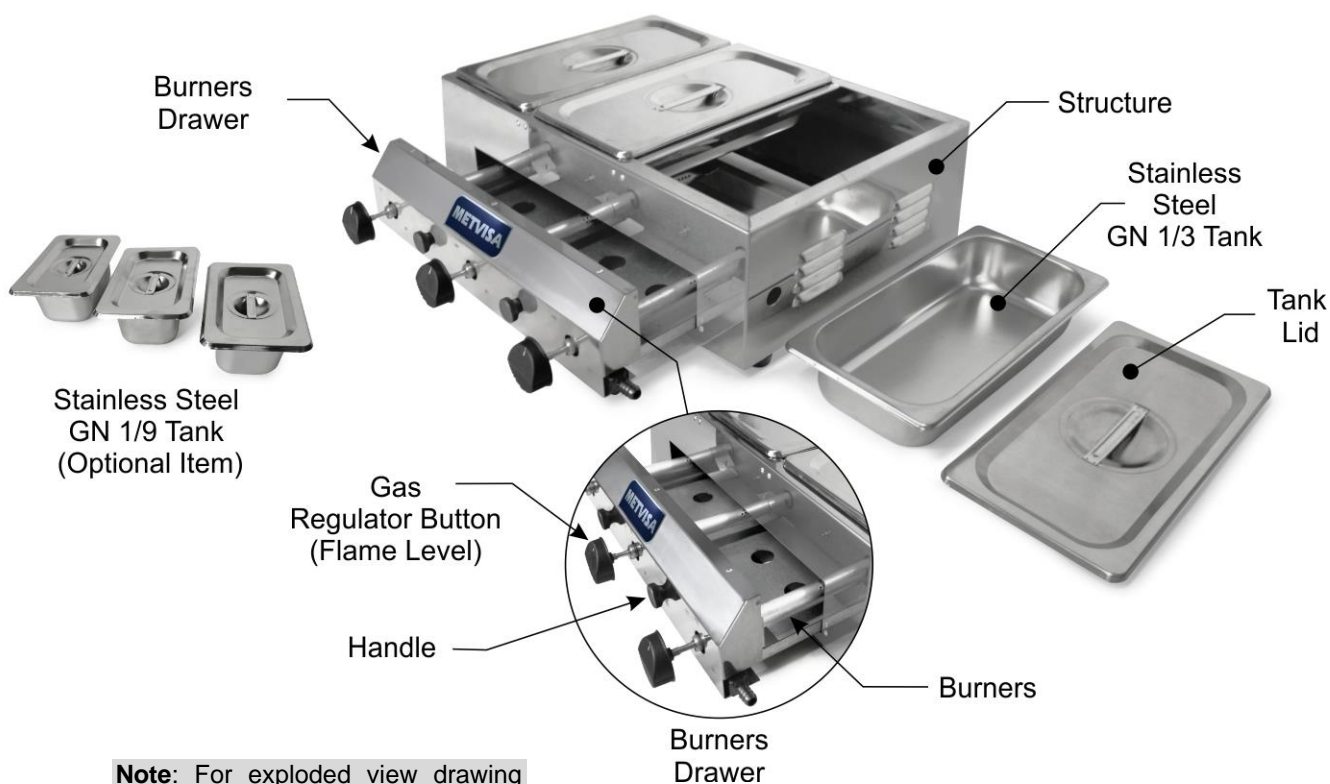

Note: For exploded view drawing with a list of spare parts, see the annexes.

2.2 Technical Data

Model	Nominal Measures for Use WidthxHeightxDepth (mm)	Net Weight (kg)	Quantity of Burners (units)	Maximum Gas Consumption (kg/h)	Quantity of Tanks (Units)	Capacity per Tank GN 1/3 (L)	Capacity per Tank GN 1/9x2,5" (L) (optional item)
MGT	570x179x440	7,0	03	0,55	03	2,5	0,6



ATTENTION!

Features like: model and serial number of the equipment are provided on the label (figure below).

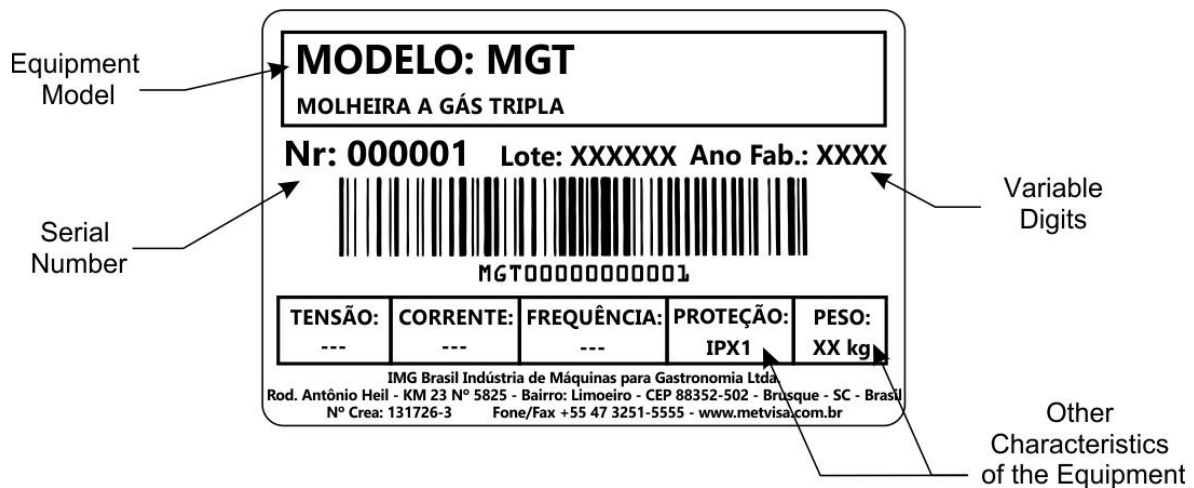

2.3 Supply and Disposal of Equipment Packaging

The equipment is packed with wood or cardboard to ensure its perfect integrity during transport and is accompanied by the following documents:

- Instruction Manual for Installation. Use, Maintenance and Safety;

IMPORTANT

The packaging components (cardboard, wood, foam, strips, etc.) are products that can be assimilated to municipal solid waste and can be disposed of without difficulty. If the equipment is installed in countries with different standards, dispose of the packaging in accordance with current regulations. Dispose of the product correctly to help protect the environment. For more information on recycling, contact your local authorities, waste disposal service or the shop where you purchased the product.

3. Installation

3.1 Equipment Layout

When installing, it is essential to make this manual available to the professionals who will carry it out.

To ensure correct operation and safety, the equipment must be positioned in an airy environment and on a sufficiently large, well-leveled, dry and stable support surface, away from sources of heat and water taps, and at an average height of 80 cm. Install your equipment leaving a distance of at least 20 cm around it, so that it has enough space for inspection, maintenance, cleaning and use.

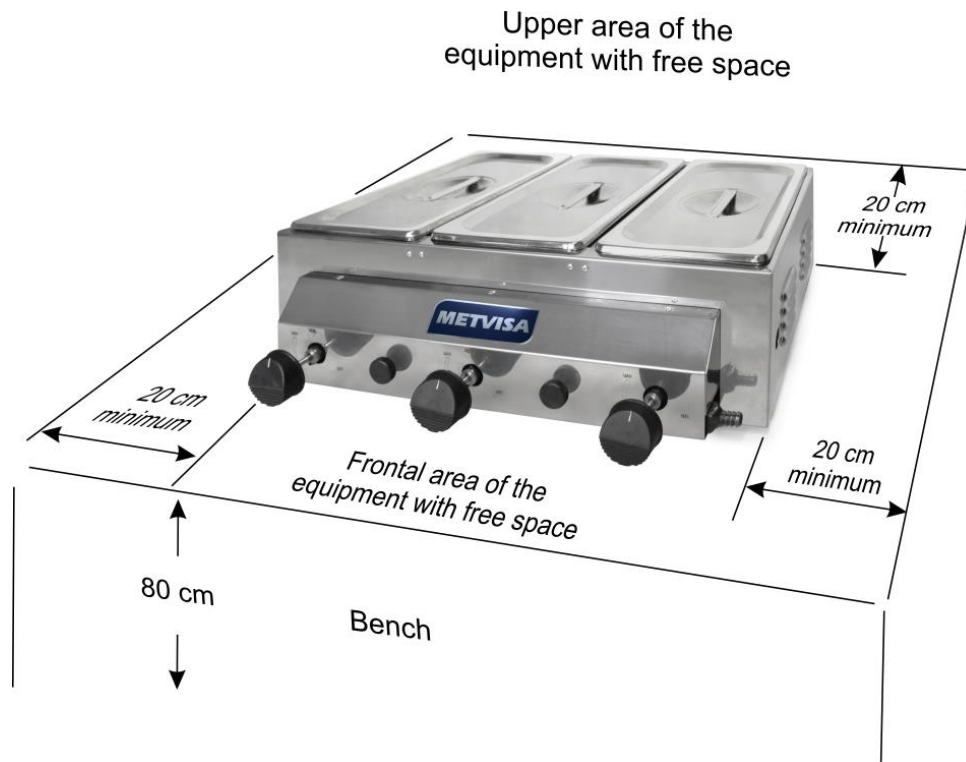

ATTENTION!

The installation and the place where the equipment will be placed must be in accordance with the Rules for the Prevention of Risks at Work and Safety at Work in Machines and Equipment (Regulatory Norm NR-12).

Do not install the equipment near flammable materials or products.

The manufacturer does not take responsibility for possible direct or indirect damage caused by failure to comply with said standards and other instructions presented in this manual.

3.2 LPG Gas Installation - Recommendations and Care

Check that the place where the equipment will be installed is ventilated and in accordance with the Rules for the Prevention of Risks at Work and Safety at Work on Machines and Equipment (Regulatory Norm NR-12), and periodic inspections by a technician are recommended to ensure that its components are in working condition.



ATTENTION!

The disposition of the equipment must be in an airy place, however that does not have airflow, thus avoiding the extinguishing of the flames in the burners, causing gas leakage.

The gas installation must be done by a qualified technician for this function and observing the safety rules.

The equipment must be installed with the following recommendations and items described below, **HOWEVER NOT PROVIDED WITH THE EQUIPMENT:**

- **Gas cylinder** - for this equipment the minimum mass is 13 kg (code P13) of LPG (liquefied petroleum gas). The cylinder must comply with ABNT 8460. Check the product's warranty seal. If it has violated, do not install.
- **Pressure Regulator or Gas Record** - use only a low pressure regulator (2.8Kpa) and certified, embossed inscription NBR 8473. When installing the regulator, turn the regulator to the right, until it is firm. Never use tools to perform this operation.
- **Hose** - the model with INMETRO certification has the engraving NBR 8613, manufactured in transparent PVC plastic with a yellow stripe. IMG fryers are manufactured with a 1/2" hose connection. The hose must not pass through or be embedded in walls, and must not make any kind of seam (welding or gluing). Fix the ends only with suitable clamps. Never use wires or tapes. Always check the expiration date of the hose.

IMPORTANT

In addition to the instructions in this manual, it is recommended to also follow the instructions of the manufacturers of cylinders, pressure regulators (gas register) and gas hoses, as these items do not accompany the equipment.



ATTENTION!

Change the pressure regulator every 5 years or when it is defective.

Always use the gas cylinder in an upright position. Never overturn, pour or tilt the cylinder, as the gas may flow into the liquid phase, canceling the pressure regulator function, which can cause serious accidents.

Never install the cylinder close to heated surfaces, and keep the conductive gas hose protected from heat so as not to melt causing fire or other accidents.



ATTENTION!

This equipment operates with LOW PRESSURE GAS. If your supply network has high pressure, have the low pressure outlet register checked by a technician. If the equipment is switched on at high pressure, the components will be damaged, in addition to creating risks for the operator.

After installation and for your safety, check for gas leaks using only soap and foam. If there is a leak, inform the technician to repeat the installation.

If the leak persists, take the cylinder to a well-ventilated location and inform the dealer or distributor of the cylinder.

IMPORTANT

The manufacturer does not take responsibility for possible direct or indirect damage caused by failure to comply with said standards and other instructions presented in this manual.

3.3 Safety Procedures and User Instruction

The professional who sells the equipment must instruct the user on the correct functioning of the equipment and must hand over this instruction manual.

The user must be informed of the necessary safety measures and must respect them, as well as all measures described in this manual.

Your equipment has mechanical protections (see item 1.2 Mechanical Safety). Removing or tampering with these safety components can cause serious risks to the operator's upper limbs.

4. Equipment Use

4.1 Utility

This equipment is exclusively intended for heating sauces and several kinds of food.



ATTENTION!

Do not use the equipment to cook food, only to heat it.

4.2 Commands

The equipment consists of gas regulating buttons (fire level) on the front. Check the adjustment positions in the following image:

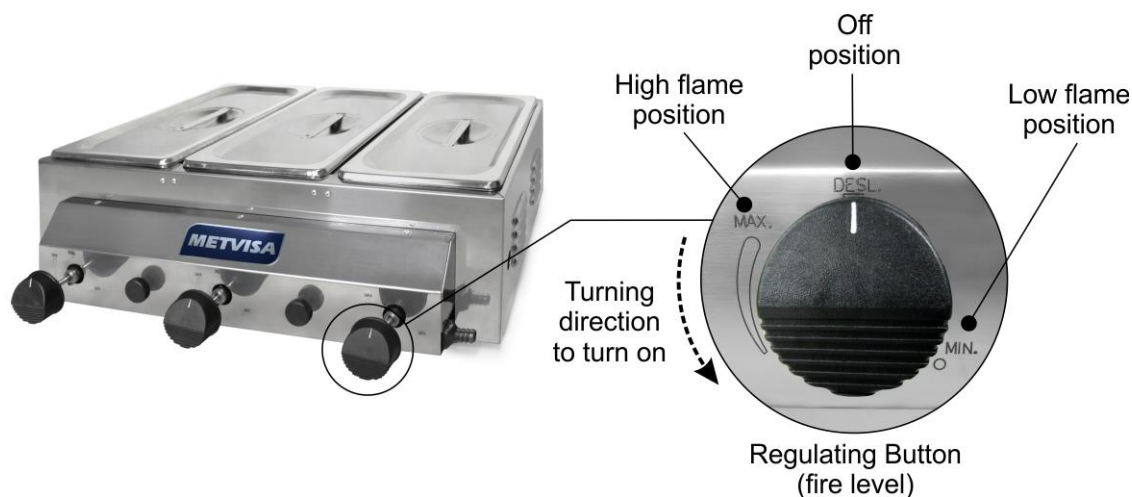

4.3 Operating Procedures

Before operating your equipment, perform perfect hygiene, especially of the components that will come into contact with food (tank and lid). Clean the equipment with the burner off, the gas

pressure regulator (gas register) closed and the frying bowl at room temperature. Follow the cleaning instructions in item 5 of this manual (below).

After these initial precautions, make sure that the gas hose connections are correctly fixed and that there are no leaks.

• **Operation:** The equipment can only be operated after checking its correct disposition in the workplace, instructed in item 3.1 (Equipment Layout), and after following the care and recommendations of the gas installation, according to the guidelines in item 3.2 (Gas Installation LPG).

Check the following operating instructions:

1. Fill each GN 1/3 tank with 2.5 liters of sauce and for the GN 1/9 tank (optional item) with 0.6 liters;
2. The lighting of the equipment is manual. Open the gas pressure register (gas register);
3. Carefully and slightly open the burner drawer;
4. Press the gas regulator button and turn to the on position;
5. For correct and safe ignition, use an automatic type igniter. With the lighter in hand, bring the tip 1 to 2 cm close to the burner for lighting;

IMPORTANT

The automatic igniter does not come with the equipment, so always check the instructions for use on the packaging, which may vary depending on the make and model.

6. Repeat the procedure for lighting each burner;
7. Adjust the fire level on the gas regulator button and observe the flame quality. The ideal flame should be blue in color. Follow the instructions below to adjust the flame:

• Each burner tube has a flame regulator, where they are preset at the factory. To set the ideal flame for each burner, make sure the burners are off and pull out the burner drawer. At the bottom of the drawer there is an opening that gives access to the clamp. Loosen (with an appropriate tool) the clamp fixing screw and slide it on the burner tube, releasing the air inlet more or less.

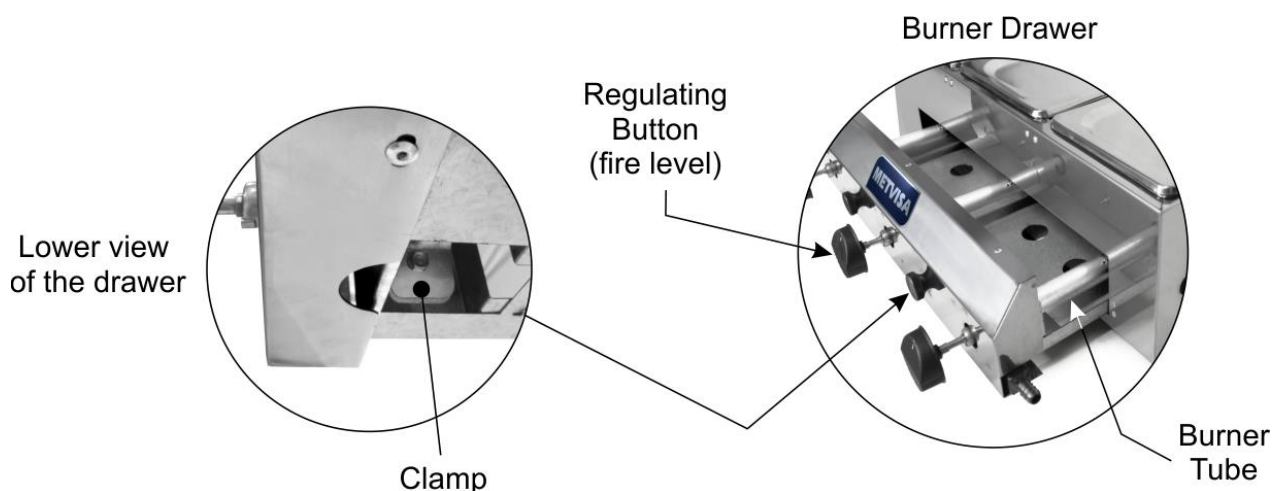



ATTENTION!

After opening the gas register, quickly light the burners, as the gas is already spreading in the air.

Light one burner at a time and make sure that the burners are completely lit.

In case of failure to ignite and you can smell gas in the environment, do not ignite.

Wait a few minutes for the air to renew in the room, and then repeat the lighting process.

8. After lighting the burners, wait for the sauce to heat up;
9. With the sauce heated, keep the heat low so as not to burn the food. This procedure also helps to save gas.



ATTENTION!

Do not exceed the maximum capacity of the tanks of 2.5 liters for the GN 1/3 model and 0.6 for the GN 1/9 model (optional item), do not overheat the sauce and do not move the equipment, this may cause overflow and splashes of hot sauce, which could cause a serious accident.



ATTENTION!

If you are going to add any ingredients to the sauce, insert the products slowly and gradually into the tank, thus avoiding bubbling and sauce spilling.

Use appropriate PPE and whenever the floor is dirty, clean it immediately.

10. After finishing the work, turn off the burners by turning the gas regulator button clockwise (off position). Close the gas pressure regulator (gas register).
11. Wait for the equipment to reach room temperature before cleaning.



ATTENTION!

After finishing the work step and switching off the burners, close the gas pressure regulator (register), because if it happens to be open, the pressure exerted on the hose may damage it or rupture, causing fire or other accidents.



ATTENTION!

During operation, hot vapors and splashes of superheated sauce or grease may be emitted. Always use PPE (Personal Protection Equipments).

5. Cleaning and Maintenance

5.1 Cleaning Procedures and Products Used

Your equipment was built with first-line materials, so use it properly and you will get great satisfaction. Keep your equipment always clean and well-cared for, which will make it much more durable.

The equipment must be cleaned daily to obtain a good operation, greater durability and avoiding the accumulation of bacteria, which can cause contamination in food.

For the protection of stainless steel parts, the equipment is supplied with a protective film. Before the first cleaning, remove the film from all parts.



ATTENTION!

Before carrying out maintenance or cleaning, make sure that the equipment has the burner turned off, the gas pressure regulator (register) closed and the tank at room temperature;



ATTENTION!

Do not use water jet to clean the equipment.

IMPORTANT

This equipment is not intended to be immersed in water for cleaning. Follow the instructions below to find out which parts can be immersed and what special care should be taken with the other parts.

Removable parts (tanks and lids) must be removed from the equipment and washed with warm water and neutral detergent. Clean the corners well, eliminating food residues.

Even though it is mobile, the burner drawer cannot be immersed in water and never use water jets for cleaning, as this will damage the burners.

When cleaning the burner drawer and structure, dilute soap, mild detergent, or ammonia-based remover in warm water and apply with a soft cloth. With a cloth dampened with water, rinse and then dry the parts with a soft, dry cloth.

Never use abrasive products or sponges and substances containing acids or chlorine to clean metal parts, as they can scratch or damage the surface of the parts causing corrosion points.



ATTENTION!

It is extremely important that products used in cleaning ensure maximum cleanliness and are non-toxic.

5.2 Maintenance and Procedures in Case of Breakdowns

The operator must be instructed to perform routine inspections, making minor adjustments, cleaning and observing signs of breaches that may occur. Examples include: check for extraneous noises indicating gas leaks; burners that do not light; failure by the equipment to perform the service for which it is proposed; among others. Actions like these are indispensable to ensure a longer equipment life.



ATTENTION!

When maintenance is carried out (even with minor adjustments), always check that the equipment has the burner turned off, the gas pressure regulator (register) closed and the tank empty;

It is also recommended to always carry out preventive maintenance, checking and adjusting clearances, cleaning the internal parts, etc. When detecting broken or poorly functioning parts, replace them, always using original parts.

By performing preventive maintenance, you eliminate the inconvenience of getting the equipment stopped when you need it most, reducing the cost of maintenance and reducing the risk of accidents.

Follow the equipment maintenance and adjustment recommendations:

- Change the gas pressure regulator (register) every 5 years or when it is defective;
- Check the expiration date of the gas hose and follow other instructions as recommended by the manufacturer;
- After finishing the frying process, keep the gas pressure regulator (register) closed, avoiding pressure in the hose;
- The gas outlet holes on the burner must always be unobstructed. If they become clogged, use a needle for cleaning on stove;
- The ideal flame should be blue. Each burner tube has a flame regulator, follow the adjustment instructions in item 4.3 (operating procedures - page 12);



ATTENTION!

Preventive maintenance requires a trained professional.

Whenever any item regarding the safety of the equipment (such as cleaning or maintenance) is removed, reset it and confirm that it is performing its function correctly.

When you experience any malfunction or non-compliance, refer your equipment to the nearest service center. See technical assistance on our website: www.metvisa.com.br

5.3 Prolonged Interruption in the Use of the Equipment

When you have to leave the equipment stopped for an extended period of time, perform a thorough cleaning, including the accessories. It is advisable to protect all parts of the equipment with white petroleum jelly or with suitable products that are commercially available. You must also protect the equipment from dust by covering it with a nylon or other material.

6. Analysis and Troubleshooting

6.1 Problems, possible causes and solutions

IMG quality products are designed with materials and components that guarantee a longer service life for your equipment. However, due to natural wear, improper use or lack of maintenance, the equipment may have irregularities in its operation.

In the following table, you can see possible causes and solutions:

PROBLEMS	POSSIBLE CAUSES	SOLUTION
Burners do not light.	Lack of gas.	Check if there is gas in the cylinder, if the gas cylinder register is open, if the gas hose is connected and if the gas regulator is open.
	Damaged or broken pressure regulator (register).	Send equipment to the nearest authorized service station or contact the factory.
	Clogged burner.	Unclog burner holes using a needle for cleaning stove nozzles, if not resolved, send the equipment to the nearest authorized service station or contact the factory.
	Lack of gas.	Below, check the possible causes and solutions for gas leak (page 16).
Yellow flame, equipment generating soot.	Problem in mixing gas with oxygen.	Each burner tube has a flame regulator, follow the adjustment instructions in item 4.3 (operating procedures page 12);
Lack of gas.	Damaged or broken pressure regulator (register).	Send equipment to the nearest authorized service station or contact the factory, as there are risks of accidents.
	Injector nozzle out of position.	Send equipment to the nearest authorized service station or contact the factory, as there are risks of accidents.
	Defective gas cylinder.	Check if has gas leakage using only soap foam. If there is a leak, inform the technician to repeat the installation. If the leak persists, take the cylinder to a well-ventilated location and inform the dealer or distributor of the cylinder.
	Gas cylinder installed in the horizontal position.	Install the cylinder in a vertical position. Never overturn, pour or tilt the cylinder, as the gas may flow into the liquid phase, canceling the pressure regulator function, which can cause serious accidents.

Difficulty adjusting the flame.	Damaged or broken pressure regulator (register).	Send equipment to the nearest authorized service station or contact the factory, as there are risks of accidents.
	Damaged or broken pressure regulator (register).	Send equipment to the nearest authorized service station or contact the factory.
Lack of gas during operation.	Lack of gas.	Check if there is gas in the cylinder, if the gas cylinder register is open, if the gas hose is connected and if the gas regulator is open.
	Damaged or broken pressure regulator (register).	Send equipment to the nearest authorized service station or contact the factory, as there are risks of accidents.

For more information and clarification, contact the Authorized Technical Assistance nearest you. See list of technical assistance on our website: www.metvisa.com.br

7. ANNEXES

Exploded View Drawing

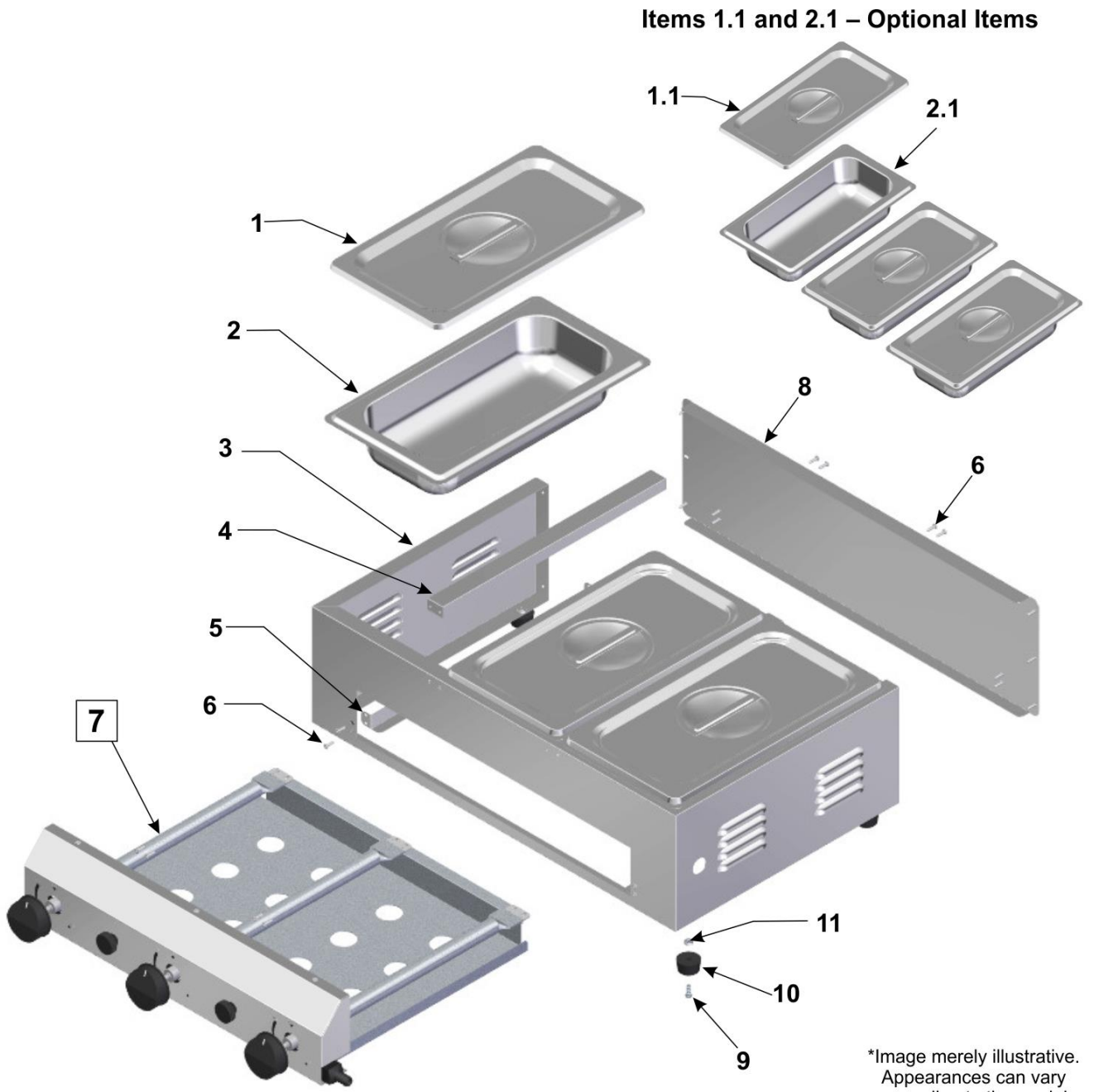

Exploded View Drawing

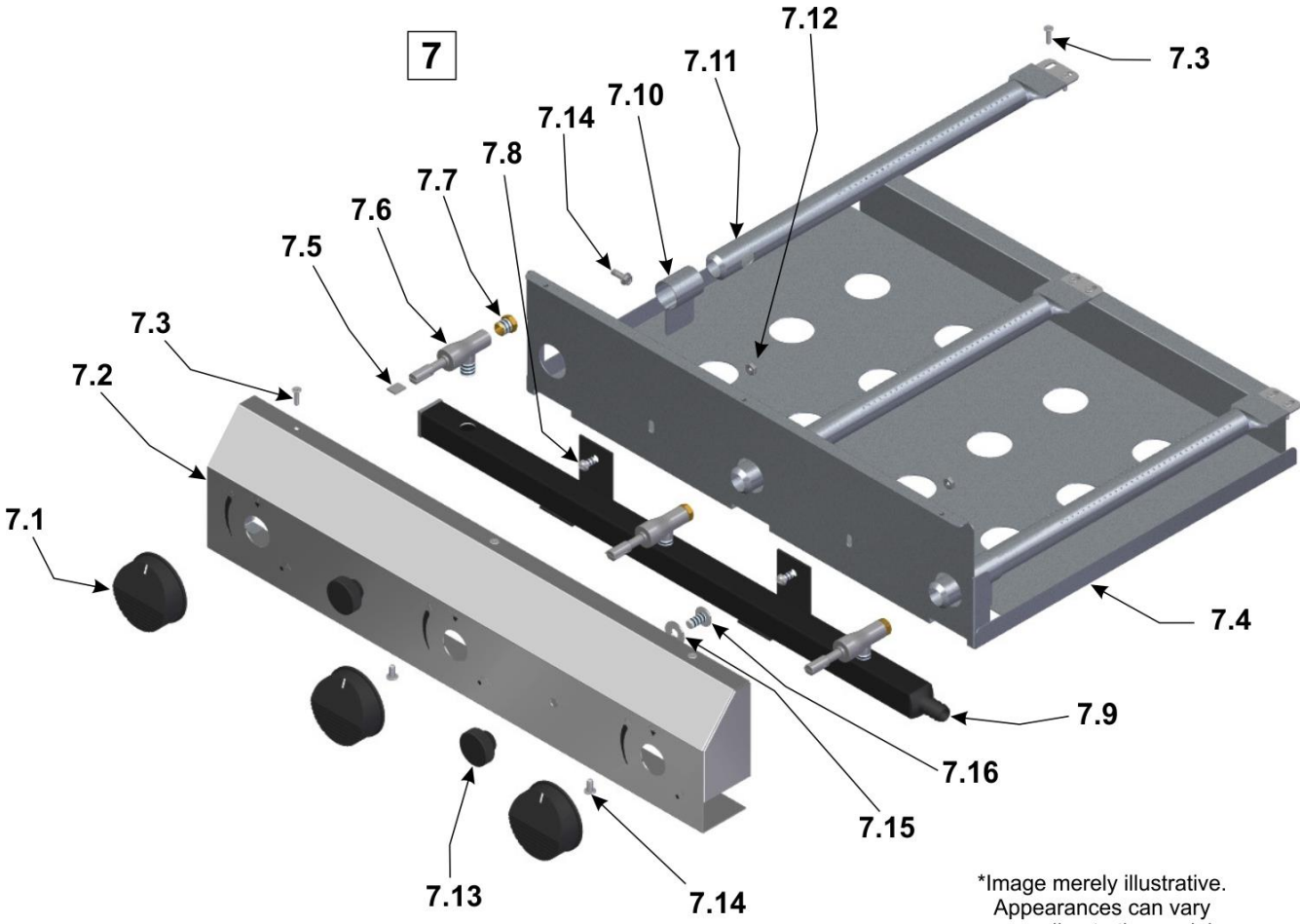
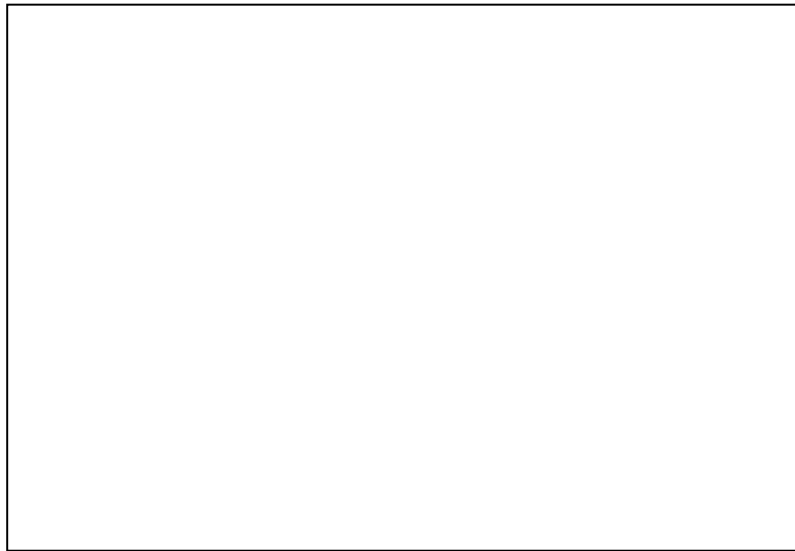

*Image merely illustrative.
Appearances can vary
according to the model.

Spare Parts

Position	Code	Description	Quantity
1	TAP179	Stainless Steel Lid GN 1/3	03
1.1	TAP177	Stainless Steel Lid GN 1/9 (optional item)	03
2	BDJ059	Stainless Steel Tank GN 1/3 x 2,5"	03
2.1	BDJ058	Stainless Steel Tank GN 1/9 x 2,5" (optional item)	03
3	GAB211	Structure	01
4	TAS119	Tank Divider	02
5	GIA101	Burner Drawer Guide	02
6	RBT002	Rivet	22
7	CJT980	Drawer with 03 Burners	01
7.1	BOT021	Gas Regulator Button	03
7.2	PTC202	Welded Front Protection	01
7.3	RBT002	Rivet	09
7.4	SBT496	Burner Support	01
7.5	CRC783	Register Support	03
7.6	TNR003	Gas Register	03
7.7	IJT006	Gas Register Injector	03
7.8	PRR005	Screw	02
7.9	CJT979	Complete Set of Welded Burner	01
7.10	CRC679	Oxygen Regulator	03
7.11	CJT946	Welded Burner	03
7.12	POS006	Hex Nut	02
7.13	MNL011	Handle	02
7.14	RBT004	Rivet	05
7.15	ARL010	Stainless Steel Flat Washer	02
7.16	PRR009	Machine Screw Round	02
8	TAP178	Back Cover of the Structure	01
9	PRR015	Machine Screw Round	04
10	PEP004	Rubber Foot	04
11	POS020	Stainless Steel Hex Nut	04

IMG BRASIL PRODUCT MANUFACTURER



IMG BRASIL Gastronomy Machinery Industry Ltda.

CNPJ 11.193.347/0001-14 - CREA 131726-3
Road. Antônio Heil - KM 23 Nº 5825 - Neighborhood: Limoeiro
ZIP CODE 88352-502 - Brusque - SC - Brazil
Phone/fax. +55 47 3251-5555 - Web Site: www.metvisa.com.br
Mail: sac@metvisa.com.br - export@metvisa.com.br



Know our complete
line of products.