

INSTRUCTIONS MANUAL

Installation | Maintenance | Usage | Safety

CHURROS MACHINE



Model

MCV.6



Image merely illustrative.



IMG BRASIL - Indústria de Máquinas para Gastronomia Ltda.

CONGRATULATIONS,

You have just purchased a IMG-BRASIL equipment, product of the highest quality, safety and efficiency.

Founded in 1989, IMG-BRASIL is a respected company as one of the best and most complete companies in the field of gastronomy equipment manufacturing.

Constant innovation and improvement of its products, using top-of-the-line raw materials, ensure superior products consumed in Brazil and in more than 25 countries worldwide.

THE RELIABILITY AND CERTAINTY OF A GOOD PRODUCT ARE IN THE NAME

IMG BRASIL PRODUCT MANUFACTURER



IMPORTANT:

PRODUCT FOR PROFESSIONAL USE. DO NOT USE BEFORE READING THE MANUAL CAREFULLY.

IN CASE OF QUESTIONS, PLEASE CONTACT US:

IMG-BRASIL Indústria de Máquinas para Gastronomia Ltda.

CNPJ 11.193.347/0001-14 - CREA 131726-3

Rod. Antônio Heil – KM 23 Nº 5825 – Bairro: Limoeiro – CEP 88352-502 - Brusque – SC – Brasil

Phone/fax. +55 47 3251-5555 - Website: www.metvisa.com.br

E-mail: sac@metvisa.com.br - vendas@metvisa.com.br

TABLE OF CONTENTS

1	Safety Information.....	4
1.1	General recommendations.....	4
1.2	Mechanical Safety	5
2.	Technical Characteristics	6
2.1	Main Components	6
2.2	Technical Data.....	7
2.3	Supply and Disposal of Equipment Packaging	7
3.	Installation.....	8
3.1	Equipment Layout	8
3.2	Safety Measures and User Instruction	9
4.	Equipment Use.....	9
4.1	Utility.....	9
4.2	Manual Operation	9
4.3	Operating Procedures.....	10
5.	Cleaning and Maintenance.....	12
5.1	Cleaning Procedures and Products Used	12
5.2	Maintenance and Procedures in Case of Breakdowns	13
5.3	Prolonged Interruption in Use of Equipment	14
6.	Analysis and Troubleshooting	14
6.1	Problems, possible causes and solutions	14
7.	Applicable Standards.....	15
8.	Annexes	16
	Exploded Design	16
	List of Replacement Parts.....	17
	Warranty Term (for Brazilian market)	18



ATTENTION!

The characteristics, pictures and figures presented in this manual should be considered for information purposes. IMG BRASIL reserves the right to make such modifications as may be deemed necessary without prior notice.

1. Safety Information

1.1 General Warnings

- Cautions / precautions must be observed when installing, using, maintaining and discontinuing use of this equipment;
- Before carrying out any operation (assembly, use (use), maintenance and reuse after prolonged use of the equipment), read the manual carefully;
- The equipment must be used by trained personnel familiar with the use and safety regulations described in this manual;

This appliance is not intended for use by persons (including children) with reduced physical, sensory or mental capacities, or people with lack of experience and knowledge, unless they have received instructions regarding the use of the device or are under the supervision of a person responsible for their safety.

- It is recommended that children be supervised to ensure that they are not playing with the equipment;
- In case of change of the personnel that will work with the equipment, the new operator must be instructed its standards and the operation;
- The operator must use the **Adequate PPE's** (equipment for individual safety). As for example: use cap on the hair avoiding that they lock in the moving parts of the equipment;
- The operator must always be aware of situations that can cause a risk of accidents and avoid them. For example: avoid working with loose uniform sleeves, where they can lock in moving parts, causing accidents;
- After being held to read and answered all the questions, this manual must be stored carefully in place of easy access, known by all the people who will operate the equipment and made available for the people who carry out maintenance, to any queries. When in doubt, consult the manual. Do not operate the equipment in any way with doubts;
- In the installation, it is essential to make this manual available to the professionals who will do the same;
- Before using your equipment, make sure it is properly secured with screws, washers and nuts on a workbench;
- Do not use your equipment without lubricating oil on the gear shafts. Only insert specific products that are intended for the equipment and never place your hands, fingers, or objects into the bowl or moving parts during use as this may cause an accident.



ATTENTION!

Do not perform repairs on your own. Refer to the technical service authorized by the manufacturer. Use only original parts in your equipment.

1.2 Mechanical Safety

- Never put your hands, fingers or objects (such as spoons and knives) into the bowl or moving parts with the equipment in use, as this may cause an accident;
- Before beginning work on your equipment, make sure that the base of the sides are secured with screws, washers, and nuts on a workbench (parts for fixing on the bench are not included with the equipment). Also check that the bowl is locked with the handle.

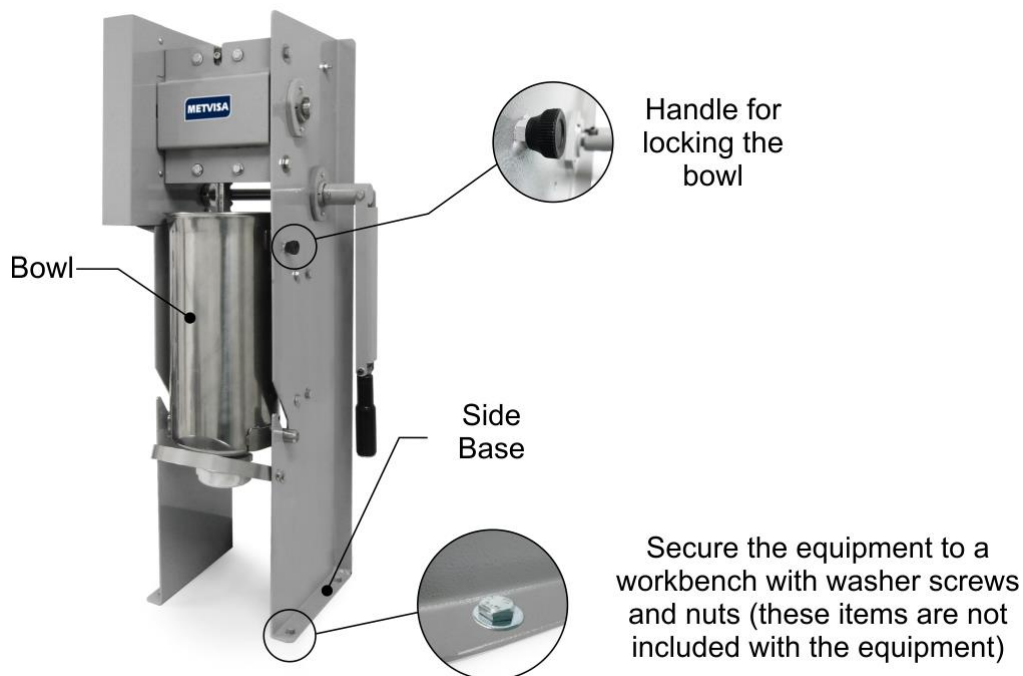

The equipment described in this manual complies with the mechanical risk regulation. Safety is obtained with:

1. Gear protection, protects the gear system, preventing operator access and contact with water, dust and other materials;
2. Handle, used to lock the bowl during processing or when transporting equipment (prevents the bowl from suddenly articulating);
3. Left and right sides, besides structuring the equipment, prevent operator access to the rack during processing;
4. O-ring of the pusher disc, scrapes the dough into the bowl during processing, preventing the dough on the sides of the bowl. This prevents the operator from scraping by other means, such as placing objects (spoons and knives) or even hands;
5. Rack support, besides supporting the rack, avoids the contact of the operator with the axle and the rack gear during the operation.

For a view of the parts described above, refer to the image in item 2.1 (Main Components) or item 6 (Attachments - Exploded View) of this manual.



ATTENTION!

Whenever any item regarding the safety of the equipment (such as cleaning or maintenance) is removed, reset it and confirm that it is performing its function correctly.

2. Technical Features

2.1 Main Components

For the equipment described in this manual, safety in use, cleaning, maintenance and maximum hygiene are guaranteed by the design and special design of all parts, and also by the use of materials suitable for contact with the dough.

The equipment was built with the following characteristics:

- All sheet metal parts, which do not come into contact with the processed product, are made of carbon steel coated with epoxy electrostatic paint, an excellent anticorrosive protection;
- Rack made of carbon steel, material of high mechanical resistance;
- Non-toxic plastic (PLA - Lactic Polyacid) churro molder nozzle, easy to material of easy conservation, hygiene and resistant to corrosion;
- Bowl, bowl support and stainless steel pusher disc, which resists the attack of various corrosive agents, such as most organic acids, organic substances in general, alkalis, oxy-sais, etc...

Note: Stainless steel is attacked by sulfuric acid, and also does not resist hydrochloric acid, diluted sulfuric acid, chlorides and halides in general.

The following are the main components of the equipment:

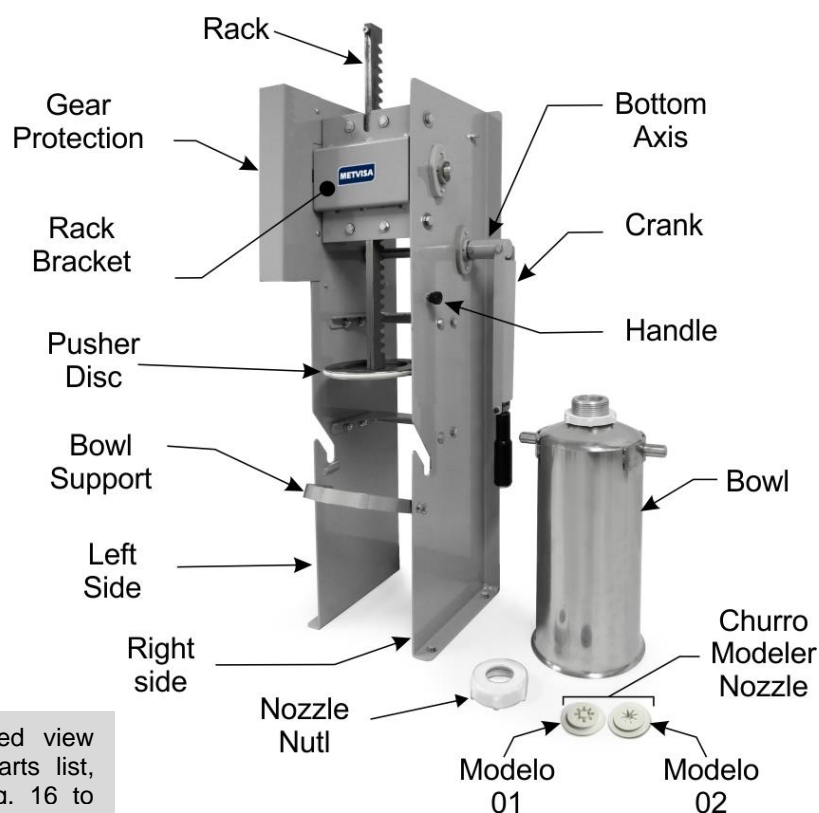

Note: for the exploded view drawing with spare parts list, see the annexes (pág. 16 to

3. Installation

3.1 Equipment Layout

Attachment of the equipment to a workbench and disposal for operation must be performed by a qualified professional.

It is essential to make this manual available to the professionals who will carry out the installation.

To ensure correct operation and safety, the machine must be positioned in an airy environment and on a sufficiently wide, level, dry and stable support surface, away from heat sources and water taps, and at a medium height of 80 cm. Install your equipment with a distance of at least 20 cm on the left side and 50 cm on the right and back side (considering the area that occupies the moving crank). At the height it is necessary to leave at least 20 cm above the rack (outwards) so that it is possible to move the bowl during the filling of the dough. Keep the frontal area free.

The layout of the equipment shall have sufficient space for inspection, maintenance, cleaning and use.

We recommend fixing the base of the sides of the equipment in a workbench with screws, washers and nuts (screws, washers and nuts for fixing in the workbench do not come with the equipment) so that there is no risk of the equipment moving during use.

For ease of transport, the crank is disassembled in the package. Mount the crank on the lower shaft with the screws, washers and nuts that come with the equipment.

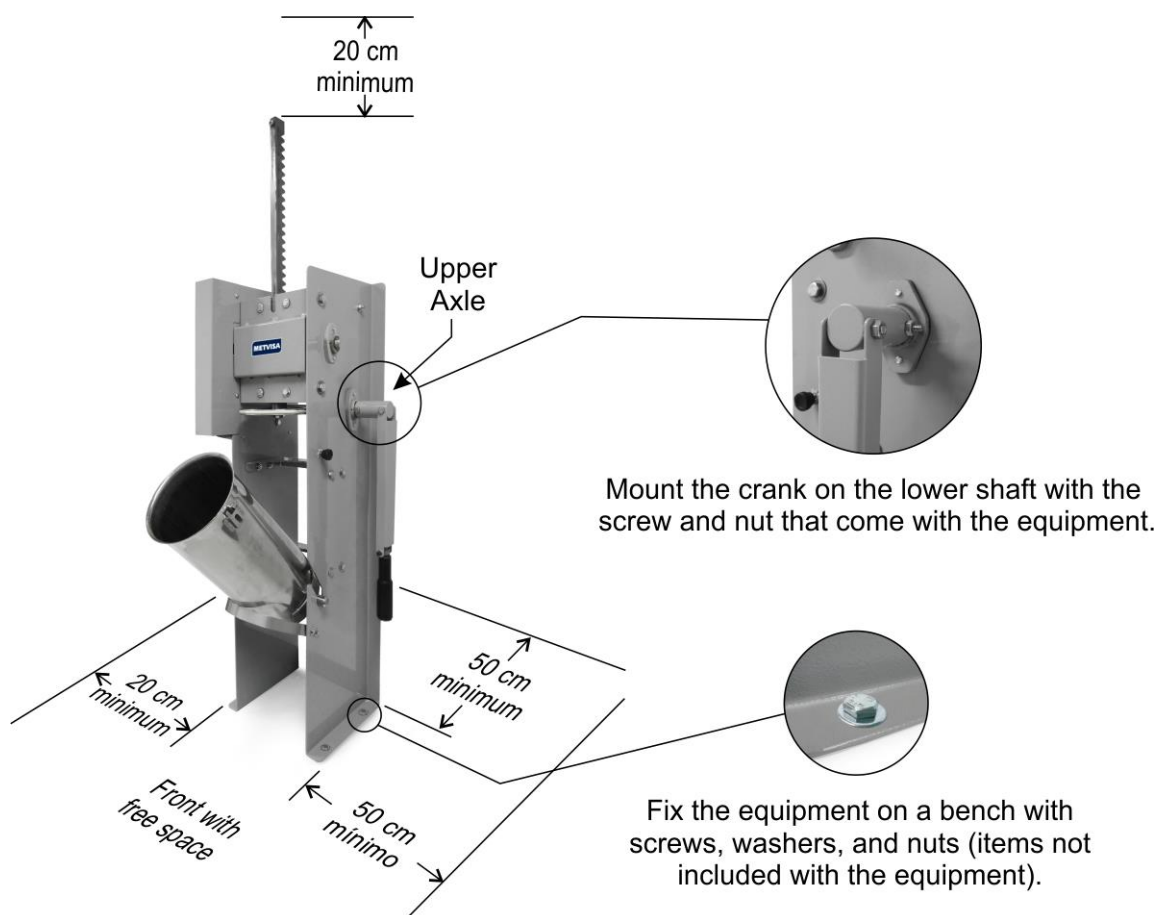



ATTENTION!

The installation and the place where the equipment will be disposed of must be in accordance with the risk prevention and work safety norms (Regulatory Standard NR-12).

The manufacturer shall not be liable for any direct or indirect damages caused by non-compliance with these standards and other instructions presented in this manual.

3.2 Safety Measures and User Instruction

The professional that makes the sale of the equipment should instruct the user about the correct operation of the equipment and should give you this instruction manual.

The user must be informed of the necessary safety measures and must respect them as well as all the measures described in this manual.

Your equipment has mechanical guards (see item 1.2 Mechanical Safety) that prevent access to moving parts. Removal or tampering with these safety components can cause serious risks to the operator's upper limbs.

4. Use of Equipment

4.1 Utility

The equipment used exclusively for extruding churro dough.

4.2 Manual Drive

The equipment consists of a crank and a handle, located on the right side plate of the equipment.

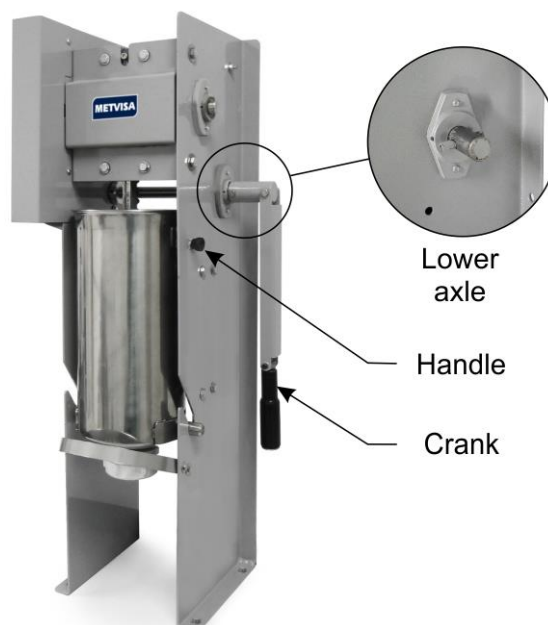

See description of each command below:

- **Crank** - used to move the pusher disc as much into and out of the bowl, pushing the dough, allowing it to be replenished. The crank should be fixed with screw and nut to the lower axle.
- **Handle** - locks the bowl making it impossible to move while processing or transporting the equipment. To lock the bowl, rotate the knob clockwise by attaching the thread to the bowl lock located on the side of the bowl. And to articulate the bowl just rotate the knob counterclockwise until it releases from the lock.

4.3 Operating Procedures

Before operating your equipment, perform a sanitization of the components that will have contact with the dough (bowl, pusher disc, nozzle, etc.). Follow the cleaning instructions in item 5 of this manual.

Check the disassembly and assembly procedure described below:

- **Disassembly:**



- **Assembly:** The assembly procedure is the reverse of disassembly. First assemble the nut of the nozzle with the modeler nozzle of your choice (model 01 or 02) in the bowl, then fit the bowl on the sides of the equipment. Lock the bowl by the handle.

①

Assemble the modeler nozzle and nut in the bowl.

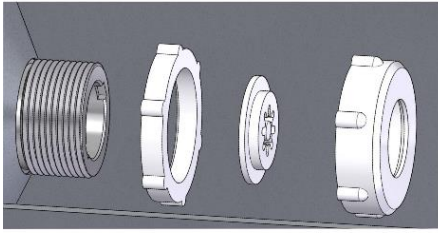

②

Fit the bowl to the sides and thread the handle into the bowl lock.



Bowl Lock

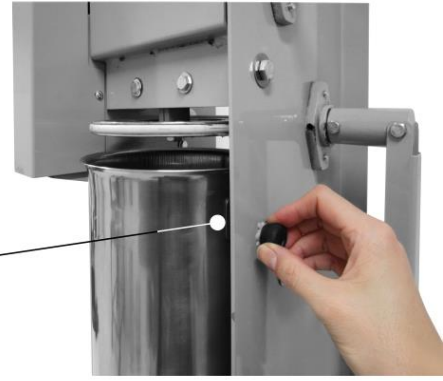

Mount all parts perfectly to ensure operator safety and proper operation of the equipment. If any part is not firm, it may not have been inserted correctly. In this case, repeat the operation and if it does not succeed, contact your service representative.

• **Operation:** Before using the equipment, make sure that all parts are properly fitted and check the correct arrangement of the equipment as instructed in item 3.1 (Equipment Layout).

Follow the procedure of operation of the equipment:

- After preparing the churro dough according to its recipe; heat the frying oil in a pot or a frying pan;
- Rotate the handle of the equipment and retract the pusher disc until it fully exits the bowl;



ATENÇÃO!

When retracting the pusher disc, it is important that there is nothing obstructing the funnel or nozzle, as the entry of air is necessary to avoid generating a vacuum and damaging the structure.

Do not leave any material obstructing the funnel when the pusher disc is retracting.

- Unscrew the handle to unlock and articulate the bowl (tilting bowl);
- Fill the bowl with the churro dough and lock the bowl by the handle;
- Rotate the crank so that the pusher disc begins to push the dough to expel through the churro molder nozzle;
- Cut the dough close to the molder nozzle to the desired size. Then put to fry in very hot oil;
- After the process is completed, clean as instructed in item 5 (Cleaning and Maintenance).



ATTENTION!

If you notice that the equipment cannot perform the process of extruding the dough, check if all the pieces are perfectly assembled and fixed, as well as if the dough is not too hard or too cold, so that it hinders the exit of the dough through the molder nozzle.

Failure to comply with these guidelines will be considered an unsafe act and abusive use of the equipment.

IMPORTANT

The operator must wear the appropriate PPE (personal protective equipment). For example: use a cap touch to prevent the hair from locking in the moving parts of the equipment and appropriate gloves that in addition to ensuring hygiene in the handling of the dough, protect the operator during food processing.

IMPORTANT

The manufacturer shall not be liable for any direct or indirect damages caused by non-compliance with these standards and other instructions presented in this manual.

5. Cleaning and Maintenance

5.1 Cleaning Procedures and Products Used

Your equipment is built with first-line materials, so use it correctly and you will get great satisfaction. Always keep your equipment clean and well taken care of, as this will make it have a much longer shelf life.

A daily cleaning of the machine must be carried out for good operation and durability.



ATTENTION!

Do not use water jet to clean the equipment.

IMPORTANT

This equipment is not intended to be fully immersed in water for cleaning. Follow the instructions below to find out which parts can be immersed and the special care to be taken with the other parts.

The dismantlable parts (bowl, nut, molder nozzle, etc.) must be removed from the equipment and washed with hot water and mild soap. Clean the corners thoroughly, eliminating residue from the dough.

With the exception of gears and axles (parts to be kept maintained lubricated with non-toxic white grease), the rest of the equipment, including the crank which is dismantlable, should be cleaned as many times as possible to prevent food residues from drying out and sticking to the pieces. For cleaning, dilute the soap or neutral detergent in warm water and apply with a soft cloth. With a cloth dampened with water, rinse and then dry the parts with a dry, soft cloth.

Never use abrasive products or sponges for cleaning as they may scratch or ruin the surface of the parts.

IMPORTANT

The manufacturer shall not be liable for any direct or indirect damages caused by non-compliance with these standards and other instructions presented in this manual.



ATTENTION!

It is extremely important that the products used in the cleaning ensure maximum cleanliness and that they are not toxic.

5.2 Maintenance and Behavior in Case of Breakdowns

The operator should be instructed to perform routine inspections by making minor adjustments and cleaning. Examples include: checking for strange noises; wear of parts; lack of lubrication of gears and axles; non-execution by the equipment to the service for which it is proposed; among others. Actions such as these are essential to ensure a longer equipment life.

It is recommended to carry out preventive maintenance every 6 months, checking and adjusting gaps, cleaning, etc. When detecting broken or malfunctioning parts, always replace using original parts.



ATTENTION!

The equipment must not be dropped or hit. Any part of the mixer that is warped or crumpled may compromise its performance or operation.

Never let your equipment work without lubricating gears and axles as this will damage your equipment.

It is recommended to lubricate parts every 6 months of use or 800 hours worked.

This equipment uses SAE 140 type lubricating oil on the axles and Food Grade Non-toxic White Grease on the gears and rack.

By performing preventive maintenance, the inconvenience of the equipment stopping when you need it most is eliminated, reducing the cost of maintenance and reducing the risk of accidents.



ATTENTION!

Preventive maintenance requires a trained professional.

Whenever an item concerning the safety of the equipment is removed (such as, for example, when performing maintenance), put it back in its proper place and confirm that it is performing its function correctly.

When you detect a breakdown or non-compliance, refer your equipment to the nearest technical assistance. See technical assistance on our website: www.metvisa.com.br

5.3 Prolonged Interruption in Use of Equipment

When you have to leave the equipment idle for an extended period of time, perform a complete cleaning, including the different accessories. It is advisable to protect all parts of the equipment with white vaseline oil or with suitable products available on the market. You should also protect the equipment from dust by covering it with a nylon screen or other material.

6. Analysis and Troubleshooting

6.1 Problems, possible causes and solutions

Products with IMG quality are designed with materials and components that guarantee longer life to your equipment. However, due to natural wear, improper use or lack of maintenance, the equipment may have irregularities in its operation.

In the following table, you can check possible causes and solutions:

PROBLEMS	POSSIBLE CAUSES	SOLUTIONS
Dough leakage through nozzle nut	- Nozzle nut or molder nozzle not properly secured.	- Unscrew the bowl nut and secure it again. Follow the disassembly and assembly procedure in accordance with item 4.3 of the manual.
		- Send the equipment to the nearest authorized service station or contact the factory.
Dough leakage in pusher disc	- Pusher disc o-ring, broken, worn or with smaller diameter.	- Send the equipment to the nearest authorized service station or contact the factory.
Heavy or locked crank.	- Lack of lubrication	It is recommended to lubricate parts every 6 months of use or 800 hours worked. This equipment uses SAE 140 type lubricating oil on the axles and Food Grade Non-toxic White Grease on the gears and rack.
	- Gears or rack with broken teeth or excess material between them.	- Send the equipment to the nearest authorized service station or contact the factory.
	- Product different from the indicated, very hard or cold dough.	- The equipment used exclusively for extruding churro dough. - If the dough is too cold, let it sit for a few hours.
	- Little dough in the bowl.	- Insert a minimum of 4 kg of dough so as not to generate pressure in the crank due to air between the dough and the pusher disc.
Equipment presents noises	- Gears or rack with broken teeth or excess material between them.	- Send the equipment to the nearest authorized service station or contact the factory.
Churros comes out deformed or torn	- Piece of hardened dough stuck to the molder nozzle.	- Follow the cleaning procedure according to item 5.1 of the manual.
	- Very hard or cold dough.	- If the dough is too cold, let it sit for a few hours.

For more information and clarifications, pcontact the nearest Authorized Technical Assistance. See technical assistance on our website: www.metvisa.com.br

7. Applicable Standards

The Brazilian standards applied for the development of the equipment and preparation of this manual are:

- NR-12 - Ordinance 197 of December 2010;
- Applicable Technical Standards (ABNT NBR, ISO IEC).

Exploded Design

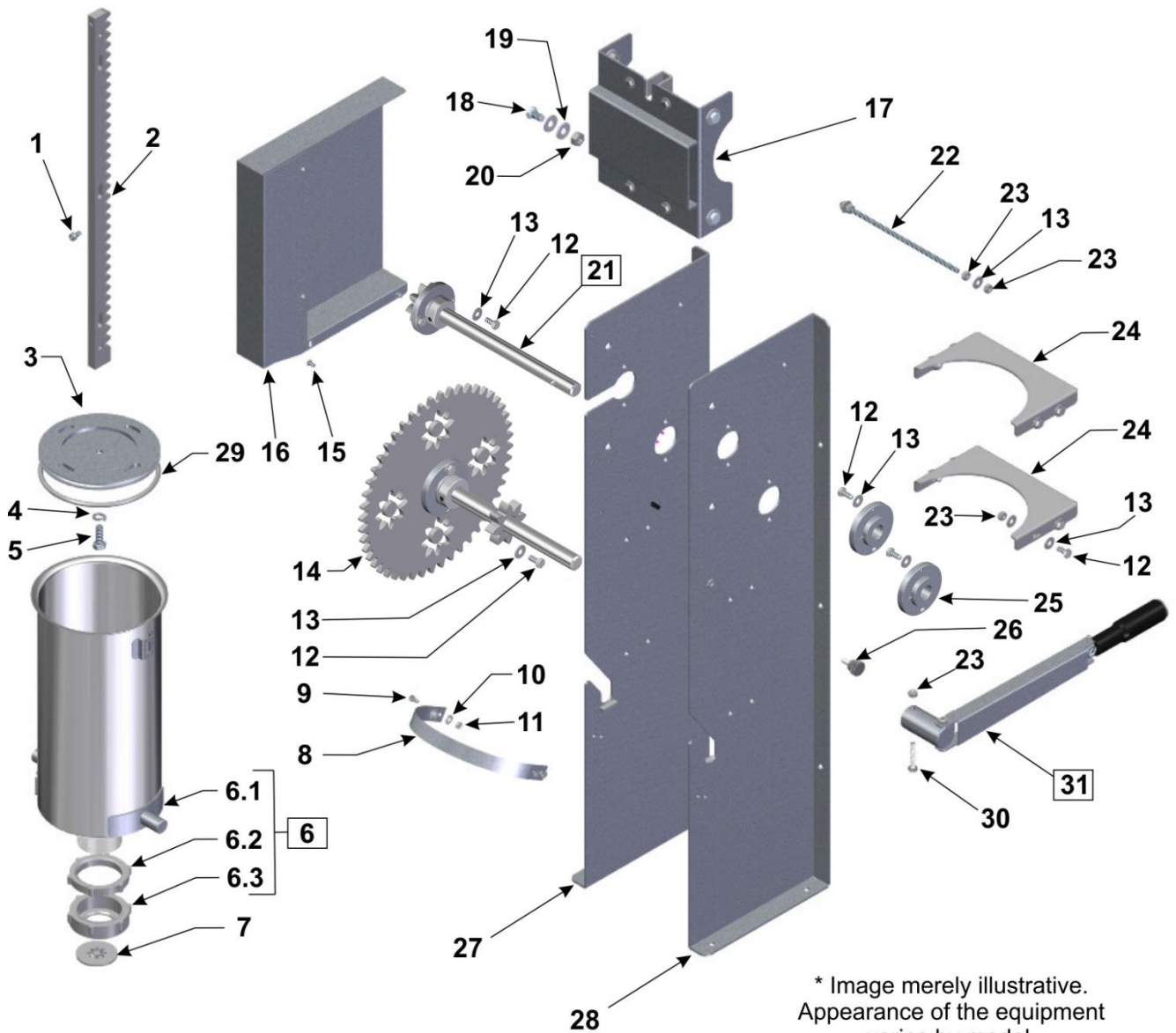

* Image merely illustrative.
Appearance of the equipment varies by model.

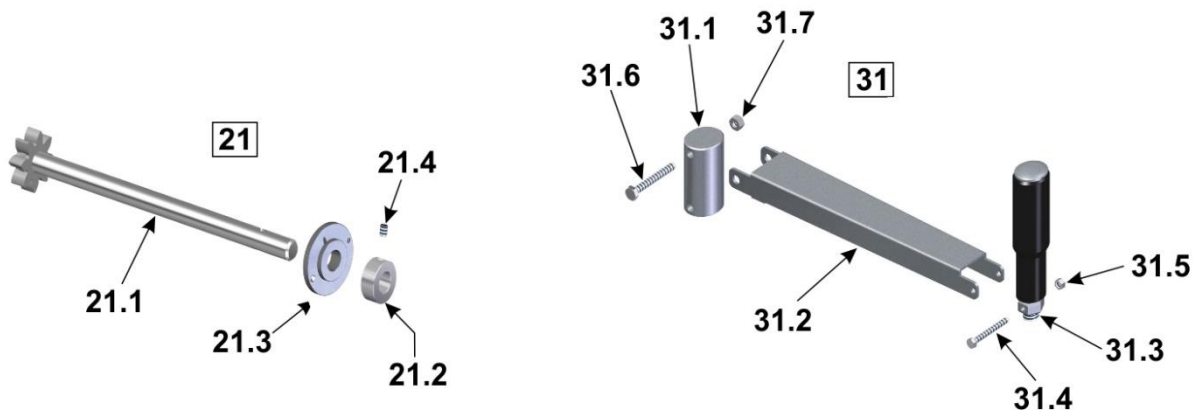

Replacement parts

Position	Code	Description	Qty.
1	PRT028	Allen Screw W/Head	01
2	CRM006	Welded Rack	01
3	FLG043	Pusher Disc	01
4	ARP002	Stainless Steel Pressure Washer	01
5	PRS023	Stainless Steel Hexagonal Screw	01
6	CJT797	Complete Bowl	01
6.1	CJT1160	Bowl with Outlet Nozzle	01
6.2	POE026	Lock Ring	01
6.3	POE001	Nozzle Nut	01
7	BAL022	Churro Molder Nozzle - Model 01	01
	BAL023	Churro Molder Nozzle - Model 02	01
8	AMP102	Bowl Support	01
9	PRS332	Stainless Steel Hexagonal Screw	04
10	ARL008	Stainless Steel Flat Washer	04
11	POS020	Stainless Steel Hexagonal Nut	04
12	PRS010	Hexagonal Screw	16
13	ARL004	Flat Washer	26
14	CJT758	Welded Top Axle	01
15	PRR005	Mach. Screw Round	04
16	PTC218	Gear Protection	01
17	CJT752	Full Rack Support	01
18	PRS027	Screw Hex.	04
19	ARL002	Flat Washer	08
20	POS003	Hexagonal Nut	04
21	CJT757	Lower Full Axle	01
21.1	CJT756	Welded Lower Axle	01
21.2	SPD049	Ring Separator	01
21.3	MAC115	Conductive Gear Bearing	01
21.4	PRN003	Allen Screw	01
22	REF064	Central Reinforcement Of Structure	01
23	POS005	Hexagonal Nut	13
24	SBT388	Side Support	02
25	MAC099	Bearing	02
26	MNL007	Handle	01
27	CJT1064	Welded Left Side	01
28	CJT1065	Welded Right Side	01
29	ORG005	O'ring Pusher disc	01
30	PRS033	Stainless Steel Hexagonal Screw	01
31	CJT804	Complete Crank Set	01
31.1	EIX242	Crank Shaft	01
31.2	CJT805	Welded Crank Plate Set	01
31.3	CJT803	Handle Set	01
31.4	PRS034	Stainless Steel Hexagonal Screw	01
31.5	POS020	Stainless Steel Hexagonal Nut	01
31.6	PRS025	Stainless Steel Hexagonal Screw	01
31.7	POS005	Hexagonal Nut	01

TERM OF GUARANTEE

(for Brazilian Market)



IMG BRASIL, manufacturer of METVISA products, undertakes to guarantee its products against possible manufacturing defects for 180 days (including 90 days of legal guarantee), counted from the date of issuance of the corresponding Sales invoice.

This WARRANTY TERM is limited to replacing defective components, excluding all electrical and / or electronic parts, which, in addition to being not guaranteed by IMG BRASIL, is subject to the conditions and norms of the original manufacturers of the damaged products.

All components that prove to be defective in their manufacture will be repaired or replaced, as the case may be, free of charge by IMG BRASIL, or any IMG BRASIL AUTHORIZED TECHNICAL ASSISTANCE, within the warranty period and with the presentation of the current WARRANTY TERM duly completed and the corresponding invoice.

This TERM OF WARRANTY does not cover damage or defects caused by:

- Usage of the equipment;
- Lack of conservation and maintenance;
- Improper storage;
- Defects in the electrical network;
- Improper installation;
- Natural wear and tear;
- Transport or inclement weather;
- Lack of use for an extended period;
- Non-compliance with technical information and guidelines.

The alteration of the product or replacement by improper, non-original components, as well as the expiration of the warranty period, render this WARRANTY TERM unenforceable.

IMG BRASIL reserves the right to modify the equipment and its components without previous notice, without having to do the same in equipment already sold.

DATA FOR PROOF OF WARRANTY

PRODUCT

Code: _____
Date of Manufacture: ____ / ____ / ____
Number: _____

INVOICE

Date of Manufacture: ____ / ____ / ____
Number: _____

CONSUMER

Stamp / Signature of Seller
Name: _____
Address: _____

DEALER

Name: _____
Address: _____

Stamp/Signature of Seller

TECHNICAL ASSISTANCE - at@metvisa.com.br

List of Technical Assistants on the site:

www.metvisa.com.br

IMG BRASIL PRODUCT MANUFACTURER



IMG-BRASIL Gastronomy Machinery Industry Ltda.

CNPJ 11.193.347/0001-14 - CREA 131726-3

Rod. Antônio Heil – KM 23 Nº 5825 – Limoeiro

CEP 88352-502 - Brusque – SC – Brazil

Phone/fax. +55 47 3251-5555 - Site: www.metvisa.com.br

E-mail: sac@metvisa.com.br - export@metvisa.com.br - export2@metvisa.com.br



Discover our complete
line of products.