



INSTRUCTION MANUAL

Installation | Maintenance | Use | Safety

Dough Sheeter



Model

CLMM.390

Image merely illustrates.

INDEX

1. Safety Information	3
1.1 General Warnings.....	3
2. Technical Features	4
2.1 Main Components.....	4
2.2 Technical Data.....	5
3. Installation	5
3.1 Machine Layout	5
4. Use of the Machine	7
4.1 Utility.....	7
4.2 Commands	7
4.3 Operating Procedures.....	8
5. Cleaning and Maintenance	10
5.1 Cleaning Procedures and Products Used	10
6. ANNEXES	12
Electrical Schematic Motor 60 Hz Voltage 110 V or 220 V.....	12
Electrical Schematic Motor 50 Hz Voltage 220 V	13
Exploded View Drawing.....	14
Replacement parts	16



ATTENTION!

The characteristics, pictures and figures presented in this manual should be considered for information. IMG BRASIL reserves the right to make such modifications as may be deemed necessary without prior notice.

1. Safety Information

1.1 General Warnings

- Cautions / precautions must be observed when installing, using, maintaining and discontinuing use of this equipment;
- Before carrying out any operation (assembly, use (use), maintenance and reuse after prolonged use of the equipment), read the manual carefully;
- The machine must be used by trained personnel familiar with the use and safety regulations described in this manual;

This appliance is not intended for use by persons (including children) with reduced physical, sensory or mental capacities, or people with lack of experience and knowledge, unless they have received instructions regarding the use of the appliance or are under the supervision of a person responsible for their safety.

- It is recommended that children be supervised to ensure that they are not playing with the equipment;
- In case of rotation of the personnel that will work with the equipment, the new operator must be educated about the standards and the operation of the same one;
- The operator must use the **Adequate PPE** (equipment for individual safety). As for example: use touches the hair avoiding that they lock in the moving parts of the machine;
- The operator must always be aware of situations that can cause a risk of accidents and avoid them. For example: avoid working with sleeves of loose uniforms, where they can lock in moving parts, causing accidents;
- After reading and clarifying all doubts, this manual should be carefully stored in an easily accessible location, known to all persons who will operate the machine and make it available to those who will carry out maintenance for any inquiries. Whenever any questions arise, be sure to check the manual. Do not operate the machine in any way with doubts;
- In the installation, it is essential to make this manual available to the professionals who will do the same;
- Never place your hands on rolling cylinders, or on or near moving parts;
- Before starting any cleaning and maintenance, it is essential to disconnect the equipment from the mains;
- Periodically check the condition of the cables and electrical parts;
- Do not leave the machine switched on unattended.



ATTENTION!

Do not perform repairs on your own. Refer servicing to qualified service personnel. Only use original parts in your machine.

2. Technical Features

2.1 Main Components

For the equipment described in this manual, safety in use, cleaning, maintenance and maximum hygiene are guaranteed by the design and special project for all parts and also by using stainless steel and other materials suitable for contact with food.

The machine was built with the following features:

- Front guard, side guards, back cover, roller support, channel, low table and slider (graduated ruler), made of stainless steel, which has superior corrosion resistance to other steels. It is a material resistant to the attack of several corrosive agents;
- The plastic scraper made of PE (polyethylene) plastic and the PVC plastic mixture roller are both non-toxic, odorless, impact and corrosion resistant materials;
- The upper and lower roller cylinders are made of stainless steel, which withstands the attack of several corrosive agents, such as most organic acids, organic substances in general, alkalis, oxysalts etc.;

Note: Stainless steel is attacked by sulfuric acid, and also cannot withstand hydrochloric acid, dilute sulfuric acid, chlorides and halides in general.

Below are the main components of the machine:

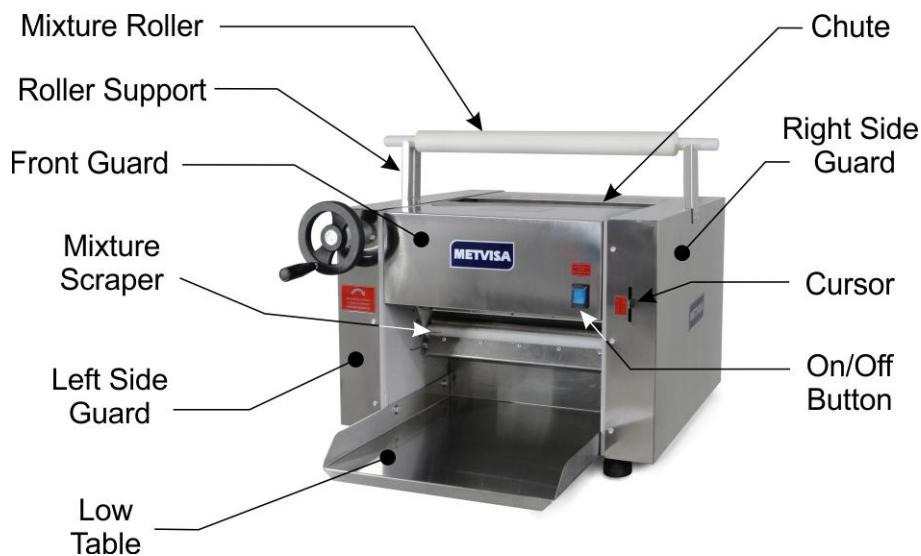

Note: For the exploded view drawing with spare parts list, see the annexes.

2.2 Technical Data

Model	Nominal Operational Measurements* Width x Height x Depth (mm)	Net weight (approx.) (kg)	Voltage (V)	Rated current (A)	Capacity (kg of mass)
CLMM390110M604	660x540x720	63.0	110	12.0	4
CLMM390220M501	660x540x720	63.0	220	5.8	4
CLMM390220M502	660x540x720	63.0	220	5.8	4
CLMM390220M504	660x540x720	63.0	220	5.8	4
CLMM390220M604	660x540x720	63.0	220	6.8	4

* Height and depth measurements considered with the mixing roll.

Noise level: 74 db.



ATTENTION!

Features like: model, serial number and voltage of the equipment are provided on the label (figure below). Before installation, check that the power supply voltage of the appliance corresponds to that of the mains.



3. Installation

3.1 Machine Layout

The connection to the mains and the arrangement for operation must be carried out by a qualified professional. Check that the machine voltage matches the mains voltage.

It is essential to make this manual available to the professionals who carry out the installation.

For ease of transportation, the machine is packed with the low table, mixing roller holder and wheel handle crank disassembled.

To mount the crank, it is necessary to thread it onto the wheel handle. The fastening of the mixing roller and the low table should be done using the washers and screws that come with the machine.

Follow the guidelines below to assemble and secure the low table:

- ① With the mixture at an angle fit the rear part behind the lower cylinder;



- ② Position the holes in the table with the holes on the sides of the machine;



- ③ Attach the table using the four screws and washers using an appropriate tool.



After fixing the table, place the machine on a stand with an average height of 80 cm in a sufficiently wide, level, dry and stable area, away from heat sources, water faucets and areas with high circulation of people. Install the machine leaving a free area on the front and a minimum distance of 50 cm on the sides and back so there is enough space for inspection, maintenance, cleaning and use.

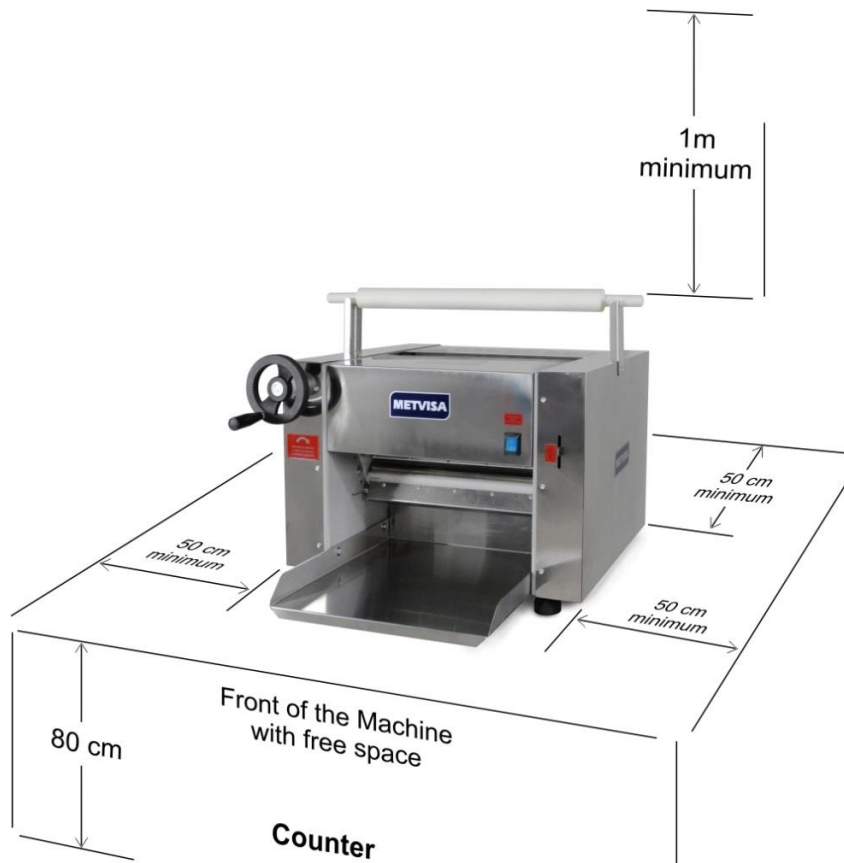

ATTENTION!

The installation and the place where the machine will be disposed must comply with the norms of risk prevention and safety at work (regulatory norm in force in your country).

The manufacturer shall not be liable for any direct or indirect damages caused by non-compliance with these standards and other instructions presented in this manual.

4. Use of the Machine

4.1 Utility

This machine is exclusively intended for rolling various food mixtures.



ATTENTION!

The machine only rolls fine mixtures (e.g. lasagna, pasties etc.). It is not suitable for kneading (e.g. bread dough).

4.2 Commands

The machine is composed of the on/off button, the wheel handle and the cursor.

The power button, wheel handle and cursor are positioned on the front of the machine.

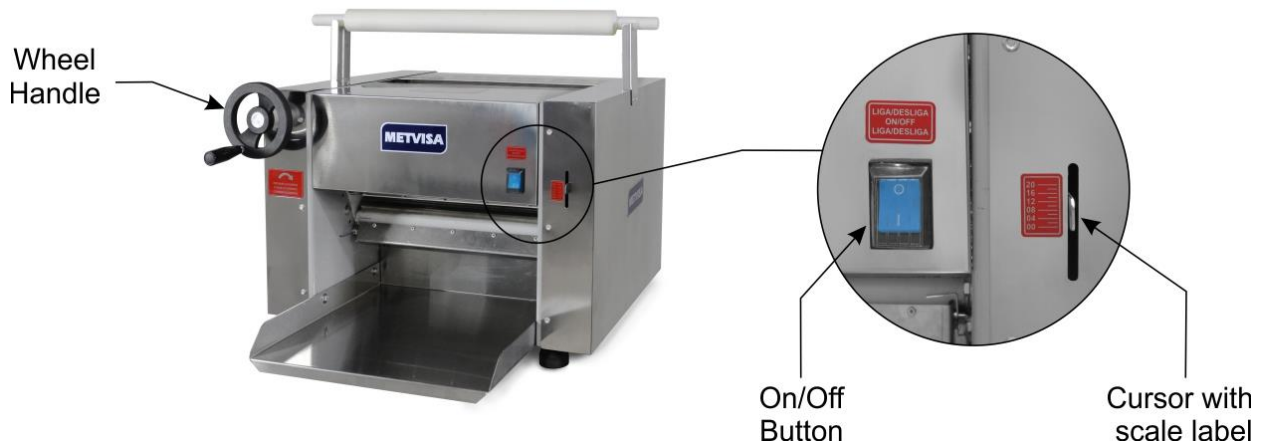

View the description of each command below:

- **On/Off Button** - Used to turn the machine on and off. In position "1" it turns the device on, and turns it off in position "0".
- **Wheel Handle** - This has the function of regulating the distance between the rolling cylinders. It should be rotated clockwise to close the cylinders and counterclockwise to open them. As the handle is rotated, the cursor will move.
- **Cursor** - Operated using the wheel handle. It indicates the thickness of the mixture by means of a marking on the cursor and the scale label.

4.3 Operating Procedures

Before operating the machine, clean it well, especially of the components that will come into contact with the mixture. Carry out cleaning with the machine disconnected from the mains. Follow the cleaning instructions in item 5 of this manual (below).

After this initial care, confirm that the supply voltage of the mains is the same as that of the machine and check the direction of rotation of the motor. To do so, start the machine and follow the rotation of the lower roller cylinder, which must be rotating clockwise according to the image below.

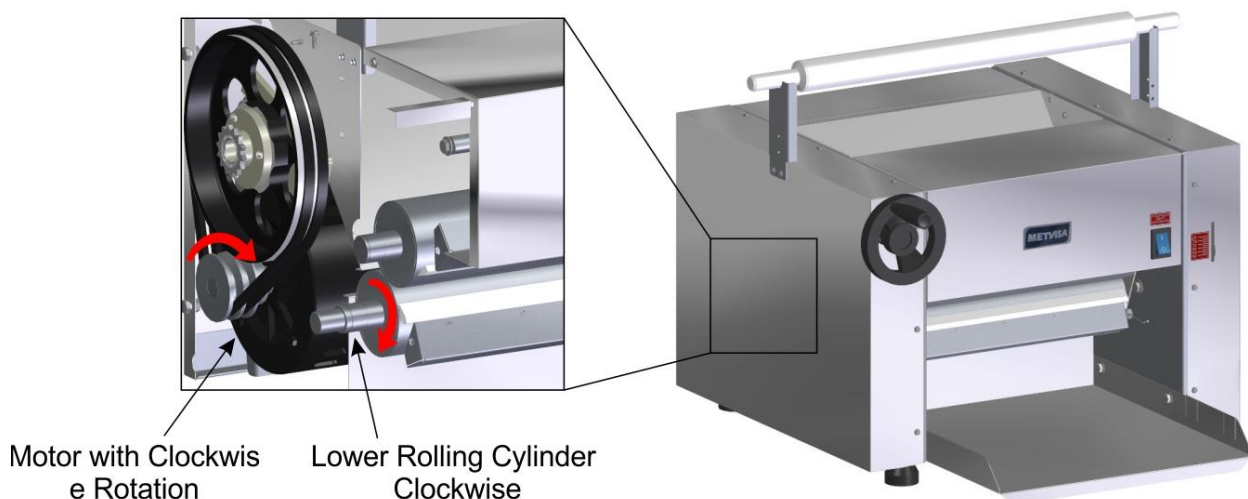



ATTENTION!

If it is rotating counterclockwise, check that the electrical connection is reversed with respect to the electrical wiring diagram (item 9 - Annexes) or contact your nearest authorized service center.

- **Operation:** The machine can only be operated after verifying its ideal positioning, if the low table is correctly fitted and fixed by the screws, according to the instructions in item 3.1 (Arrangement of the Machine).

After checking these items, follow the operating procedure of the machine:

- Connect the power cord to the mains;
- Open the cylinders at the maximum (cursor at position 20 on the scale);
- Turn the power switch to "1" (on) and leave the machine on for a few seconds;
- Position it in front of the low table and throw some flour into the chute (enough for the mixture to slide through);
- Place the mixture in the chute so that it is conducted by the cylinders, ensuring that your hands do not pass the front guard on the machine;
- Remove the mixture from the low table;
- Close the cylinders gradually until the ideal thickness is obtained;
- When the mixture is longer than the low table surface, wrap the mixture on one of the rollers and fit it onto the support. Guide the end of the mixture into the duct and unwind it until it is conducted by the cylinders. Using the second roller, roll up the mixture again;
- After the process is completed, switch off the machine by switching the power button to the "0" (off) position.



ATTENTION!

If the dough is stuck in the chute or one of the guards, turn the machine off by switching the power button to the "0" (off) position, unplug the mains cord, and remove the mixture safely. Throw more flour into the chute and perform the rolling operation again as instructed above.



ATTENTION!

Do not add all of the mixture at once with the cylinders closed. If you still notice that the machine cannot process the mixture or that it is not processing, decrease the amount.

Only increase the mixture gradually so as not to impair the motor speed and performance, as well as the working life of the machine.

Failure to comply with these guidelines will be considered an unsafe act and abusive use of the machine.

In the case of any irregularities please contact your nearest authorized service center.



ATTENTION!

Never place your hands, fingers or objects (such as spoons and knives) directly into the cylinders with the machine turned on as this may cause an accident.

5. Cleaning and Maintenance

5.1 Cleaning Procedures and Products Used

Your machine was built with first-line materials, so use it properly and you will obtain great satisfaction. Always keep your machine clean and well-cared for, which will make it much more durable.

Daily cleaning of the machine must be carried out for good operation and durability.



ATTENTION!

Before performing maintenance or cleaning, make sure that the appliance is switched off and that the plug is disconnected from the mains.



ATTENTION!

Do not use water jet to clean the machine.

IMPORTANT

This machine is not intended to be immersed in water for cleaning. Follow the instructions below to find out which parts can be immersed and the special care to be taken with the other parts.

The removable part (mixing roller) must be removed from the machine and washed with water and neutral soap. The remainder of the machine should be cleaned as many times as possible to prevent the residue of the mixture from drying out and sticking to the parts. For cleaning, dilute soap or mild detergent in warm water and apply with a damp, soft cloth on the cylinders and the outside of the machine. With a cloth moistened with water, rinse and then wipe the parts with a dry cloth. Clean the corners well, eliminating residue from the flour and mixture.

Never use abrasive products or sponges for cleaning as they may scratch or ruin the surface of the parts. Do not spill water on the motor and electrical parts for cleaning, as turning it on afterwards may cause electric shock or even burn the machine.



ATTENTION!

It is extremely important that the products used in cleaning ensure maximum cleanliness and are not toxic.

6. ANNEXES

Electrical Schematic Motor 60 Hz Voltage 110 V or 220 V

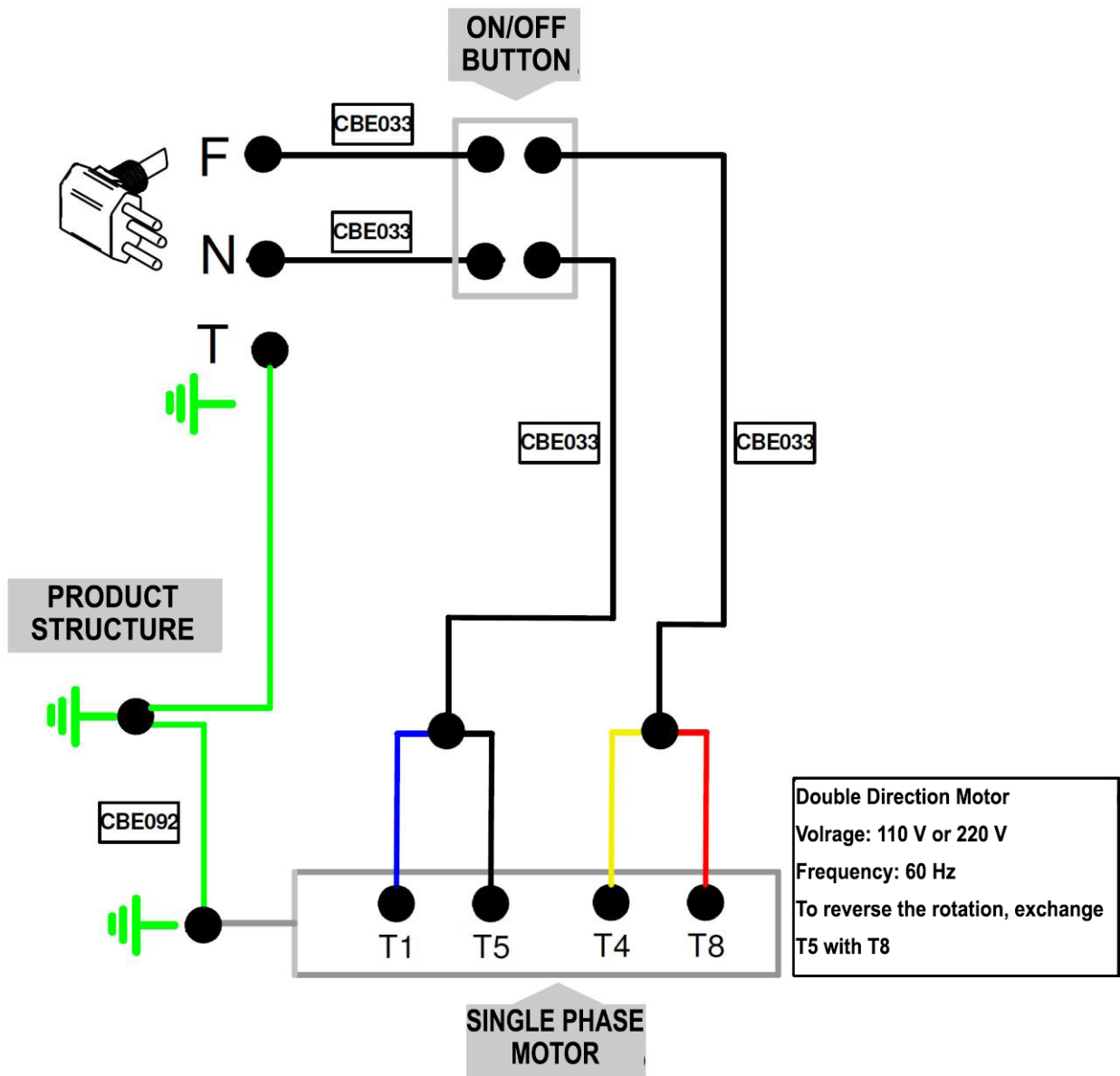

Electrical Schematic Motor 50 Hz Voltage 220 V

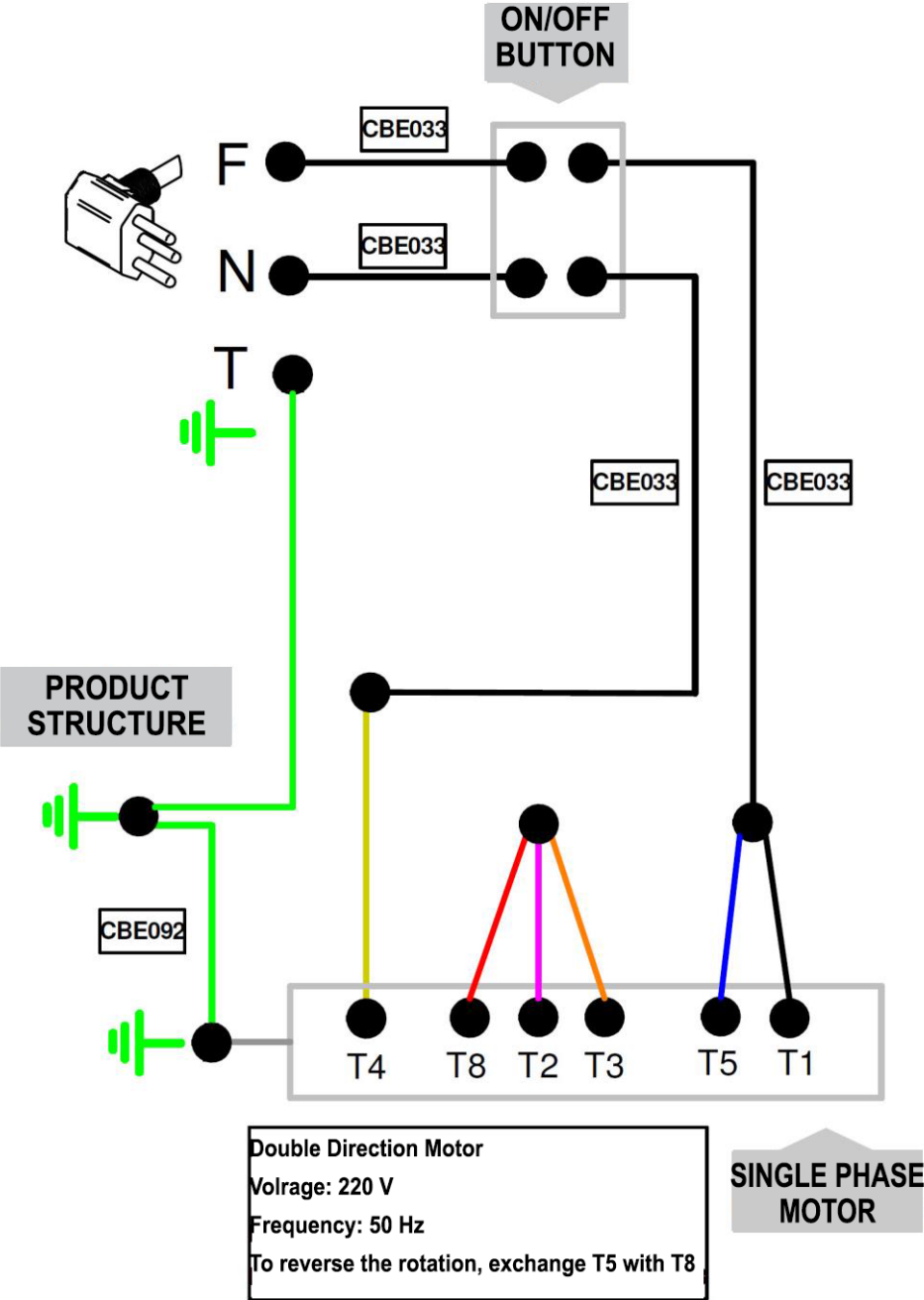

NOTE: In the above Electrical Schematic, white wires are represented by pink.

Exploded View Drawing

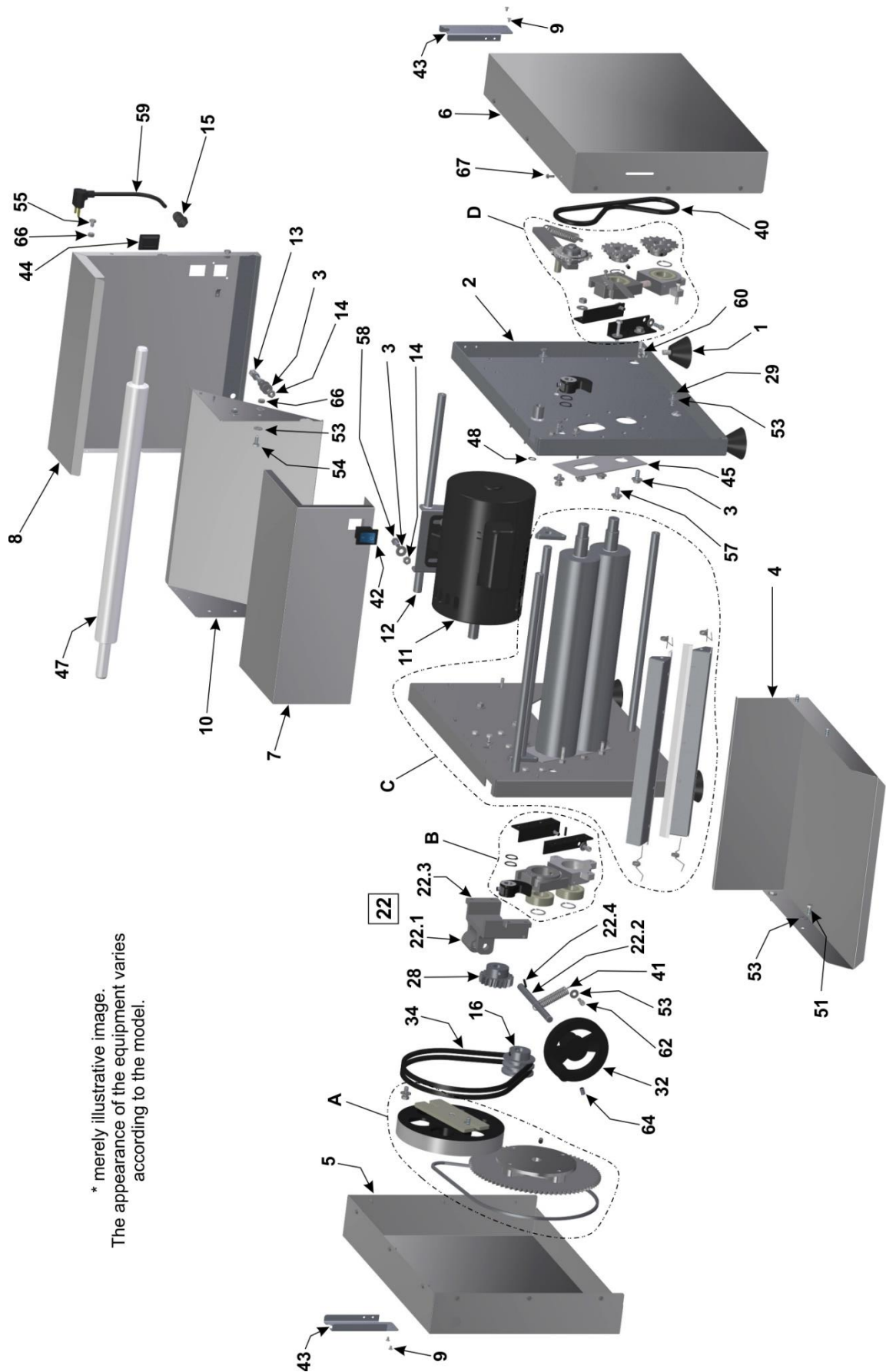

* merely illustrative image.
The appearance of the equipment varies
according to the model.

Exploded View Drawing

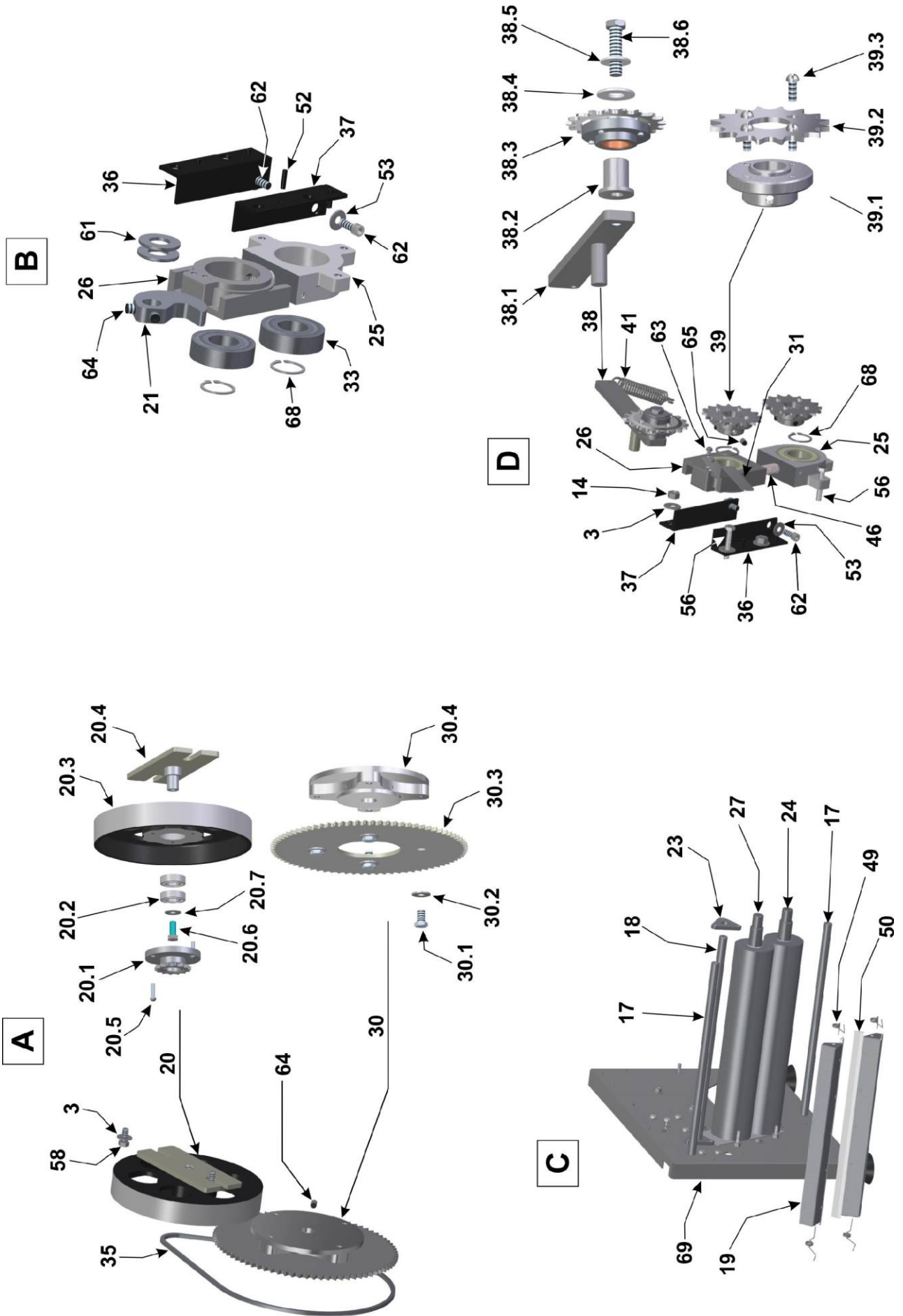

Replacement parts

Position	Code	Description	Qty.
1	PEP028	PVC Foot	04
2	CRC356	Welded Right Side	01
3	ARL003	Flat Washer	32
4	MSA015	Low Table	01
5	PTC160	Welded Left Side Guard	01
6	PTC161	Welded Right Side Guard	01
7	PTC155	Front Guard	01
8	TAP154	Rear Cover with Reinforcement	01
9	RBT014	Rivet	08
10	CLH013	Chute	01
11	MTE245	Electric Motor 1 HP 60 Hz 220 V	01
	MTE028	Electric Motor 1 HP 50 Hz 220 V	01
	MTE244	Electric Motor 1 HP 60 Hz 110 V	01
12	CJT801	Welded Motor Support	01
13	PRS012	Hexagonal Screw	01
14	POS004	Hexagonal Nut	19
15	TCE073	Print Cable 220 V	01
	ARE047	Print Cable 220 V Washer	02
	TCE019	Print Cable 110 V	01
16	PMT026	Motor Pulley	01
17	SPD050	Side Spacer	02
18	EIX237	Cam Articulator Shaft	01
19	CJT786	Mounted Mixture Scraper	02
20	CJT258	Pulley Mounted on the Support	01
20.1	EGG044	Cube with Gear	01
20.2	ROL002	Bearing	02
20.3	POL011	Movement Pulley	01
20.4	SBT042	Movement Pulley Support	01
20.5	PRR012	Screw	03
20.6	PRS007	Hexagonal Screw	01
20.7	ARL003	Flat Washer	01
21	CAM001	Cams	02
22	CJT1085	Left Bearing Assembly	01
22.1	EGG014	Worm Gear	01
22.2	EIX146	Worm Gear Shaft	01
22.3	MAC082	Left Bushing of the Cam Shaft	01
22.4	PNL006	Elastic Pin	01
23	MAC069	Cam Shaft Bushing	02
24	CIL024	Lower Cylinder	01
25	MAC071	Lower Cylinder Bushing	02
26	MAC070	Regulator Cylinder Bushing	02
27	CIL023	Upper Cylinder	01
28	EGG042	Gear	01
29	PRS018	Hexagonal Screw	06
30	CJT260	Mounted Gear	01
30.1	PRS027	Hexagonal Screw	04
30.2	ARL002	Flat washer	04
30.3	EGG043	Gear	01
30.4	CUB005	Gear Hub	01
31	CRC365	Cursor	01
32	MNL032	Cylinder Regulator Wheel Handle	01
33	ROL010	Bearing	04
34	COR005	Belt	02
35	CRT016	Chain	01
36	CAN037	Left Corner Bushing Guide	02
37	CAN036	Right Corner Bushing Guide	02

Replacement Parts

Position	Code	Description	Qty.
38	CJT264	Mounted Stretcher	01
38.1	HAT023	Welded Stretch Lever	01
38.2	SPD019	Stretcher Spacer	01
38.3	CJT263	Gear	01
38.4	ARL001	Flat washer	01
38.5	PRS002	Hexagonal Screw	01
39	CJT262	Gear	02
39.1	CUB007	Gear Hub	01
39.2	EGG028	Gear	01
39.3	PRR015	Screw	04
40	CRT015	Chain	01
41	MOL009	Stretcher Spring	03
42	CHE016	On/Off button	01
43	SBT416	Plastic Roller Support	02
44	BCH046	Rectangular Cap	01
45	TCM019	Cylinder Backboard	02
46	MOL008	Tipper Locking Spring	02
47	RLO018	Mixing Roller	02
48	APE005	Retaining Ring	01
49	MOL027	Right Scraper Spring	02
50	MOL026	Left Scraper Spring	02
51	PRD062	Hexagonal Screw	04
52	PNL006	Elastic Pin	08
53	ARL004	Flat Washer	33
54	PRS010	Hexagonal Screw	08
55	PRS014	Hexagonal Screw	10
56	PRS033	Stainless Steel Hex Screw	04
57	PRS008	Hexagonal Screw	06
58	PRS007	Hexagonal Screw	10
59	CBE001	Power Cable - CLMM390220M604 / CLMM390220M504	01
	CBE007	Power Cable - CLMM390220M502	01
	CBE020	Power Cable - CLMM390220M501	01
	CBE002	Power Cable - CLMM390110M604	01
60	POS017	Hexagonal Nut	04
61	ARL009	Flat Washer	04
62	PRT005	Allen Screw w/Head	05
63	PRR005	Mac. Screw Round	02
64	PRN001	Allen Screw S/C	09
65	PRN003	Allen Screw S/C	06
66	POS005	Hexagonal Nut	08
67	PRA014	Locking Hex. Screw	30
68	APE006	Retaining Ring	04
69	CRC699	Welded Left Side	01
70	CBE033	Cable Splicing	04
71	CBE092	Ground Cable Splicing	01
72	TCE004	Terminal FIT	04
73	TCE013	Female Terminal	01
74	TCE033	Threaded Connector	05

Notes

IMG BRASIL PRODUCT MANUFACTURER



IMG-BRASIL Gastronomy Machinery Industry Ltda.

CNPJ 11.193.347/0001-14 - CREA 131726-3

Rod. Antônio Heil – KM 23 Nº 5825 – Limoeiro

CEP 88352-502 - Brusque – SC – Brazil

Phone/fax. +55 47 3251-5555 - Site: www.metvisa.com.br

E-mail: sac@metvisa.com.br - export@metvisa.com.br - export2@metvisa.com.br



Discover our complete
line of products.