



# INSTRUCTION MANUAL

Installation | Maintenance | Use | Safety

## Industrial Blender



### Models

LQ.4 / LQL.4

LQ.6 / LQL.6

LQ.8 / LQL.8

LQ.10 / LQL.10

Model: LQL.10

Image merely illustrates.

# TABLE OF CONTENTS

<b>1. Safety Information</b> .....	<b>3</b>
1.1 General Warnings.....	3
<b>2. Technical Features</b> .....	<b>4</b>
2.1 Main Components.....	4
2.2 Technical Data.....	5
<b>3. Installation</b> .....	<b>6</b>
3.1 Equipment Layout.....	6
<b>4. Use of the Device</b> .....	<b>7</b>
4.1 Utility.....	7
4.2 Commands .....	7
4.3 Operating Procedures.....	8
<b>5. Cleaning and Maintenance</b> .....	<b>10</b>
5.1 Cleaning Procedures and Products Used .....	10
5.2 Maintenance and Procedures in Case of Malfunctions.....	11
<b>6. ANNEXES</b> .....	<b>13</b>
Electrical Scheme - Voltage 110 V - 60 Hz .....	13
Electrical Scheme - Voltage 220 V - 50 Hz or 60 Hz.....	14
Exploded Design .....	15
Replacement parts .....	16



## **ATTENTION!**

The characteristics, pictures and figures presented in this manual should be considered for information. IMG BRASIL reserves the right to make such modifications as may be deemed necessary without prior notice.

# 1. Safety Information

## 1.1 General Warnings

- Cautions / precautions must be observed when installing, using, maintaining and discontinuing use of this device;
- Before carrying out any operation (assembly, utilization (use), maintenance and reuse after prolonged use of the equipment), read the manual carefully;
- The equipment must be used by trained personnel familiar with the use and safety standards described in this manual;

This device is not intended for use by persons (including children) with reduced physical, sensory or mental capacities, or people with lack of experience and knowledge, unless they have received instructions regarding the use of the device or are under the supervision of a person responsible for their safety;

- It is recommended that children be supervised to ensure that they are not playing with the equipment;
- In case of change of the personnel that will work with the equipment, the new operator must be educated about the standards and the operation of the same one;
- The operator must use the **Adequate PPE's** (equipment for individual safety). As for example: use touches the hair avoiding that they lock in the moving parts of the machine;
- The operator must always be aware of situations that can cause a risk of accidents and avoid them. For example: avoid working with loose uniform sleeves, where they can lock in moving parts, causing accidents;
- After being held to read and answered all the questions, this manual must be stored carefully in place of easy access, known by all the people who will operate the equipment and made available for the people who carry out maintenance, to any queries. Whenever any questions arise, be sure to check the manual. Do not operate the device in any way with doubts;
- Before starting cleaning and any maintenance, it is essential to disconnect the device from the power supply;
- Periodically check the condition of the cables and electrical parts;
- In the installation, it is essential to make this manual available to the professionals who will do the same;
- Never place hands, fingers or objects inside the cup while the device is on, as this could cause an accident;
- Never turn on the device with the cup uncovered, and also don't remove the cup while the device in operation;
- Do not leave the equipment switched on unattended.



### **ATTENTION!**

**Do not perform repairs on your own. Refer servicing to qualified service personnel. Use only original parts in your device.**

## 2. Technical Features

### 2.1 Main Components

For the equipment described in this manual, safety in use, cleaning, maintenance and maximum hygiene are guaranteed by the design and special project for all parts, as well as by using stainless steel and other materials suitable for contact with food.

The device was built with the following features:

- **Lid** made of non - toxic plastic (polyethylene - PE). Material resistant to citric acid (found in lemon and orange juice), is easy to maintain, hygienic and resistant to corrosion;
- **Cup** manufactured in stainless steel, which resists the attack of several corrosive agents, such as the majority of the organic acids, organic substances in general, alkalis, oxy-salts, etc..

**Note: stainless steel is attacked by sulfuric acid, and also cannot withstand hydrochloric acid, diluted sulfuric acid, chlorides and halides in general.**

- **Cabinet** made of stainless steel, which has higher corrosion resistance than other steels. It's a material resistant to the attack of several corrosive agents;
- The **blades** are made of 301 hardened stainless steel, which increases wear resistance. Very resistant to aggressive agents such as fruit and vegetable juices, some mild acids and alkalies, water vapor free of contaminants, etc.
- **Cup base and support** for LQ equipment.4/6/8/10 are produced in high strength aluminum for LQL equipment.4/6/8/10 are produced in non-toxic ABS plastic that is resistant to impact.

See the following for the main components of the device:



Note: for the exploded view drawing with spare parts list, see the annexes.

## 2.2 Technical Data

Model	Nominal Measures Length.xHt.xWidth (mm)	Net Weight (kg)	Voltage (V)	Rated current (A)	Capacity (L)
LQ4110M604	230x615x230	11.1	110	6.8	4
LQ4220M501	230x615x230	11.8	220	3.5	4
LQ4220M502	230x615x230	11.8	220	3.5	4
LQ4220M504	230x615x230	11.8	220	3.5	4
LQ4220M604	230x615x230	11.1	220	4.0	4
LQ6110M604	230x680x230	11.2	110	6.8	6
LQ6220M501	230x680x230	11.9	220	3.5	6
LQ6220M502	230x680x230	11.9	220	3.5	6
LQ6220M504	230x680x230	11.9	220	3.5	6
LQ6220M604	230x680x230	11.2	220	4.0	6
LQ8110M604	230x760x230	11.7	110	9.0	8
LQ8220M501	230x760x230	12.7	220	5.1	8
LQ8220M502	230x760x230	12.7	220	5.1	8
LQ8220M503	230x760x230	12.7	220	5.1	8
LQ8220M504	230x760x230	12.7	220	5.1	8
LQ8220M604	230x760x230	11.7	220	5.1	8
LQ10110M604	230x840x230	12.1	110	9.0	10
LQ10220M501	230x840x230	13.5	220	5.1	10
LQ10220M502	230x840x230	13.5	220	5.1	10
LQ10220M503	230x840x230	13.5	220	5.1	10
LQ10220M504	230x840x230	13.5	220	5.1	10
LQ10220M604	230x840x230	12.1	220	5.1	10
LQL4110M604	230x615x230	9.4	110	6.8	4
LQL4220M501	230x615x230	9.7	220	3.5	4
LQL4220M502	230x615x230	9.7	220	3.5	4
LQL4220M504	230x615x230	9.7	220	3.5	4
LQL4220M604	230x615x230	9.4	220	4.0	4
LQL6110M604	230x680x230	9.6	110	6.8	6
LQL6220M501	230x680x230	9.8	220	3.5	6
LQL6220M502	230x680x230	9.8	220	3.5	6
LQL6220M504	230x680x230	9.8	220	3.5	6
LQL6220M604	230x680x230	9.6	220	4.0	6
LQL8110M604	230x760x230	9.8	110	9.0	8
LQL8220M501	230x760x230	10.0	220	5.1	8
LQL8220M502	230x760x230	10.0	220	5.1	8
LQL8220M504	230x760x230	10.0	220	5.1	8
LQL8220M604	230x760x230	9.8	220	5.1	8
LQL10110M604	230x840x230	10.2	110	9.0	10
LQL10220M501	230x840x230	10.3	220	5.1	10
LQL10220M502	230x840x230	10.3	220	5.1	10
LQL10220M503	230x840x230	10.3	220	5.1	10
LQL10220M504	230x840x230	10.3	220	5.1	10
LQL10220M507	230x840x230	10.3	220	5.1	10
LQL10220M604	230x840x230	10.2	220	5.1	10

Noise level: 82 dB.



### ATTENTION!

Features like: model, serial number and voltage of the equipment are provided on the label (figure below). Before installation, check that the power supply voltage of the appliance corresponds to that of the mains.

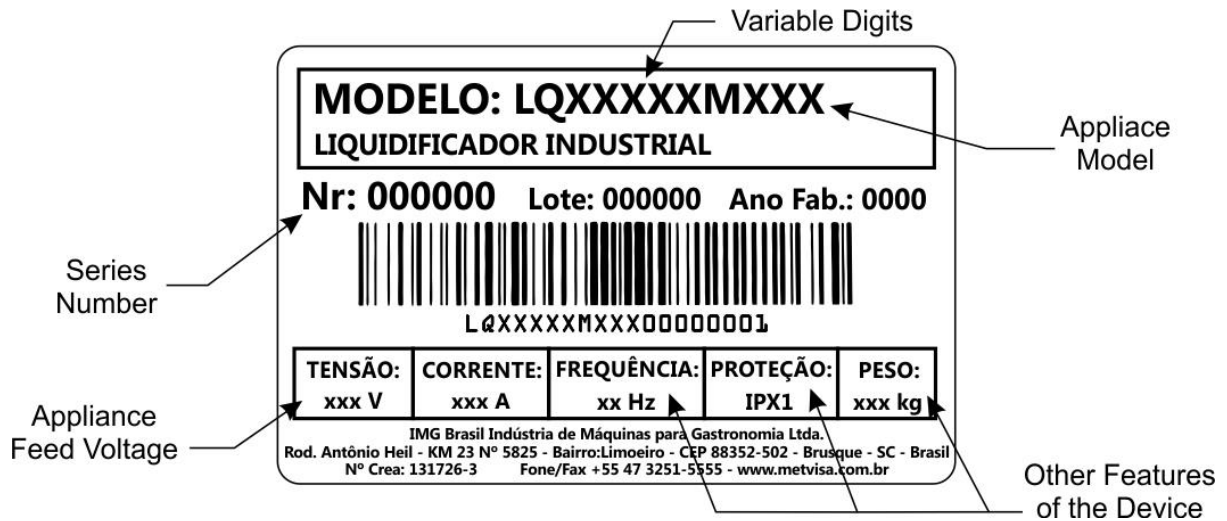

### 3. Installation

#### 3.1 Equipment Layout

The connection to the mains and the arrangement for operation must be carried out by a qualified professional. Check that the voltage of the equipment matches the mains voltage.

- It is essential to make this manual available to the professionals who carry out the installation.

To ensure correct operation and safety, the machine must be positioned in an airy environment and on a sufficiently wide, level, dry and stable support surface, away from heat sources and water taps, and at a medium height of 80 cm. Install your appliance by leaving a distance of at least 20 cm around it so that it has sufficient space for inspection, maintenance, cleaning and use.





## ATTENTION!

The installation and location of the appliance must be in accordance with the regulations on the prevention of risks and safety at work (regulatory standard in force in your country).

The manufacturer shall not be liable for any direct or indirect damages caused by non-compliance with these standards and other instructions presented in this manual.

## 4. Use of the Device

### 4.1 Utility

This appliance is intended exclusively for the grinding of food products with the addition of liquid.

### IMPORTANT

For dense foods such as: some types of mayo, cake dough or savory dough the use of the LQ line is recommended.

LQ and LQL blenders are not suitable for crushing cassava, similar or very dense foods.

### 4.2 Commands

The appliance is composed of only the on/off switch, positioned on the front of the cabinet.



See button description:

- **On/Off Button** - used to turn the device on and off. In position "1" turns on, in position "0" turns off.

### 4.3 Operating Procedures

Before operating your device, make sure that the items that come into contact with the food (cup, lid and overcap) are perfectly clean. Perform cleaning with the appliance disconnected from the electrical network. Follow the cleaning instructions in item 5 of this manual.

Make sure the cup protection is securely attached to the glass. Make sure that the cup is firmly inserted in the coupling and cup holder. Also check that the supply voltage of the device (110 V ou 220 V) complies with that of the power grid.

After verifying these items, follow the operating procedures of the device:

- Connect the power cord to the power grid;
- Add the liquid according to your recipe, but always comply with the "MAX" level indicated on the cup. In possession of the pre-cut pieces of food (approximately 2 cm), place them in the cup;

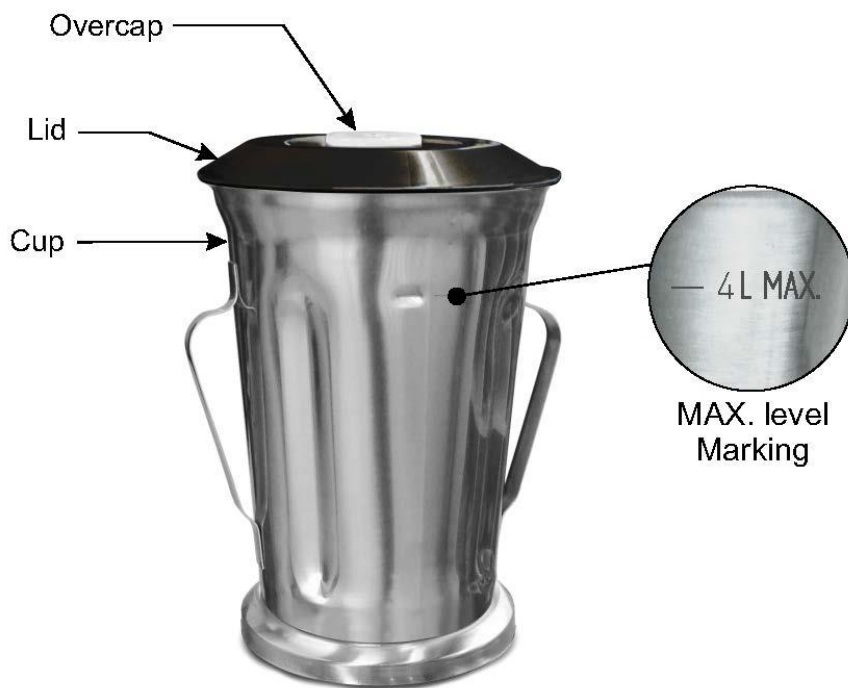

#### ATTENTION!

To avoid damaging the device, never turn it on with the glass empty. Before connecting it, insert liquid in the minimum amount at twice the height of the blade.



- Before plugging in your device, always lock the cover with the overcap on the cup;
- To start processing, press the on/off button in the "1" (on) position;
- To add ingredients during processing, remove the overcap by turning it counterclockwise and pulling it up vertically. Use the opening in the cover without needing to remove it;
- Allow time necessary to process food properly;
- After the process is completed, turn the device off by pressing the on/ off button in the "0" position (off) and remove the device from the socket.

### **IMPORTANT**

**When processing a liquid that is hot, remove the overcap to allow steam to escape. For your safety, the temperature of the processed products must not exceed 40° C.**

**If food sticks to the wall of the cup, turn off the appliance and unplug the device from the socket. Use a spatula to remove food from the wall of the cup.**

**To add ingredients or for viewing the food being processed, remove only the overcap.**

**Never turn on the device with the cup uncovered, and also don't remove the cup while the device is in operation.**



### **ATTENTION!**

**Do not put your fingers, hands or objects (such as spoons and knives) into the glass as this may cause accidents.**



### **ATTENTION!**

**Do not leave the appliance running for more than 3 uninterrupted minutes. If processing has not finished after that time, let it stand for 10 minutes before putting it back into operation.**

**To avoid damaging the device, never turn it on with the glass empty.**

**Ice crushing is not recommended. For grinding of solid foods add liquid, otherwise overheating may occur, damaging the cup sealing system, wear and/or breaking of the blades and other components of the device.**

**If you notice that the device cannot process the food or that it stops processing, decrease the amount or size of the food in the pre-cut before inserting it into the cup.**

**For very dense foods such as: some types of mayo, cake dough or savory dough, the use of the LQ line is recommended.**

**Failure to comply with these guidelines will be considered an unsafe act and abusive use of the device.**

**In the case of any irregularities contact your nearest authorized service center.**

## 5. Cleaning and Maintenance

### 5.1 Cleaning Procedures and Products Used

Your equipment is built with first-line materials, so use it correctly and you will get great satisfaction. Keep your equipment always clean and well taken care of, as this will make it have a much longer shelf life.

A daily cleaning of the machine must be carried out for good operation and durability.



#### **ATTENTION!**

**Before performing maintenance or cleaning, make sure that the on/off switch is in the "0" (off) position and the plug is disconnected from the power grid.**



#### **ATTENTION!**

**Do not use a water jet to clean the appliance.**

#### **IMPORTANT**

**This equipment is not intended to be fully immersed in water for cleaning. Follow the instructions below to find out which parts can be immersed and the special care to be taken with the other parts.**

To remove heavier dirt from the cup, follow the instructions below:

1. Insert the cup into the coupling and cup holder;
2. Add lukewarm water and a few drops of neutral detergent into the glass;
3. Place the cover and turn the device on for a few seconds;
4. When the appliance is turned off, remove the cup from the holder and rinse in running water.

The removable parts (cover and top cover) must be removed from the appliance and washed with neutral soap and water. Clean the corners thoroughly, eliminating food residue.

The rest of the appliance should only be cleaned with a damp cloth as many times as possible to prevent food residues from drying out and sticking to the parts. Dry all cleaned parts with a soft, dry cloth.

Never use abrasive products or sponges and substances containing acids or chlorine to clean the metallic parts, as they may scratch or damage the surface of the parts causing corrosion points. Do not spill water on the engine and electrical parts for cleaning, otherwise, turning it on may cause electric shock or even burn the device.



### **ATTENTION!**

Take care when cleaning the cup, because the blades are extremely sharp. Handle with care, otherwise it could cause accidents. The same attention is paid to any other sharp component of the device.

### **IMPORTANT**

The manufacturer shall not be liable for any direct or indirect damages caused by non-compliance with these standards and instructions presented in this manual.



### **ATTENTION!**

It is extremely important that the products used in the cleaning ensure maximum cleanliness and are not toxic.

## **5.2 Maintenance and Procedures in Case of Malfunctions**

The operator must be instructed to perform routine inspections, making minor adjustments, the cleaning and to observe signs of breakdowns that could occur. Examples include: checking for extraneous noise; loss of power of the appliance; the non-performance by the appliance of the service to which it proposes; among others. Actions such as these are essential to ensure a longer equipment life.



### **ATTENTION!**

When maintenance is made (even if small adjustments), always unplug the appliance from the mains.



### **ATTENTION!**

The blades may be re-sharpened when they lose their cut. To do this, contact the nearest technical assistance.

It is recommended to carry out preventive maintenance every 6 months, checking and adjusting clearances, cleaning internal parts, etc.. When detecting broken or malfunctioning parts, always replace using original parts.

By carrying out preventive maintenance, the inconvenience of keeping the device still when needed most is eliminated, the cost of maintenance is reduced and the risk of accidents is reduced.



## **ATTENTION!**

**Preventive maintenance requires a trained professional.**

**Make sure the device is disconnected from the power grid.**

**Whenever an item related to the safety of the device is removed (e.g. when performing maintenance), put it back in its proper place and confirm that it is performing its function correctly.**

When a breakdown or non-compliance is detected, refer your device to the nearest technical assistance. See technical assistance on our website: [www.metvisa.com.br](http://www.metvisa.com.br)

## 6. ANNEXES

### Electrical Scheme - Voltage 110 V - 60 Hz

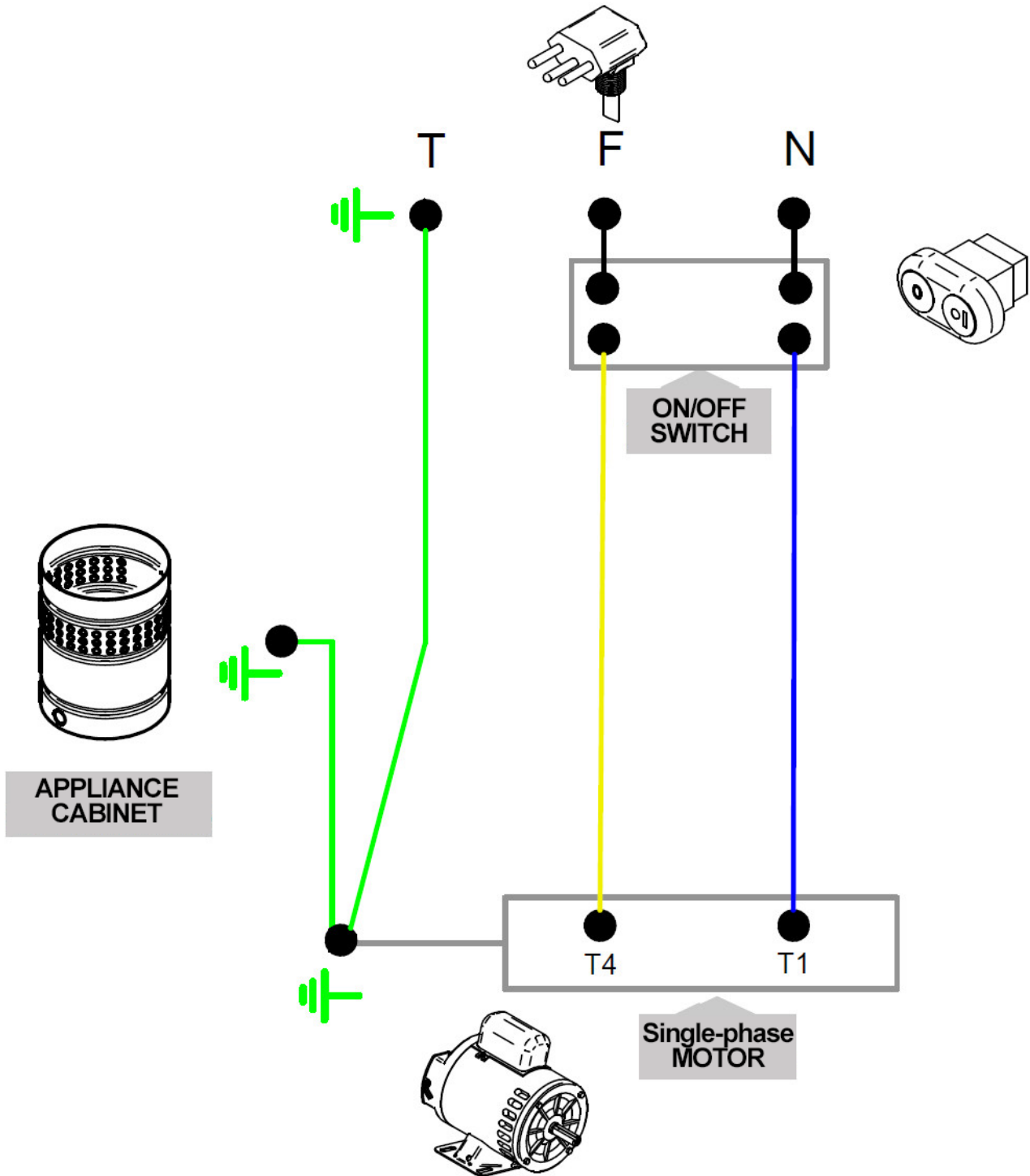

**ATTENTION:** The ground connection varies according to the type of plug. For electrical installation observe the current standards of the country, especially with regard to ground connection (if applicable).

## Electrical Scheme - Voltage 220 V - 50 Hz or 60 Hz

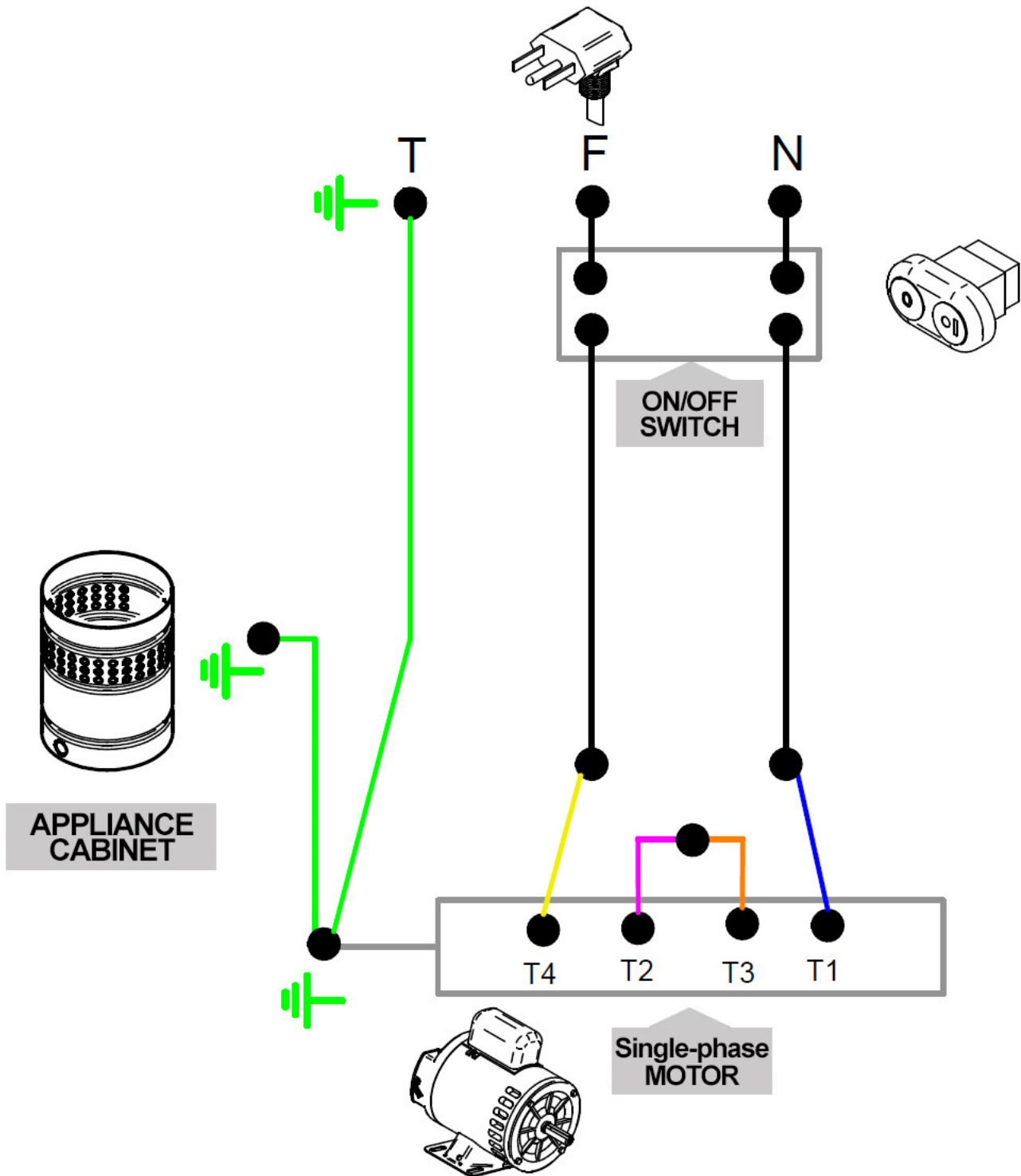

**NOTE:** In the above Electrical Schematic, white wires are represented by pink.

**ATTENTION:** The ground connection varies according to the type of plug. For electrical installation observe the current standards of the country, especially with regard to ground connection (if applicable).

# Exploded Design

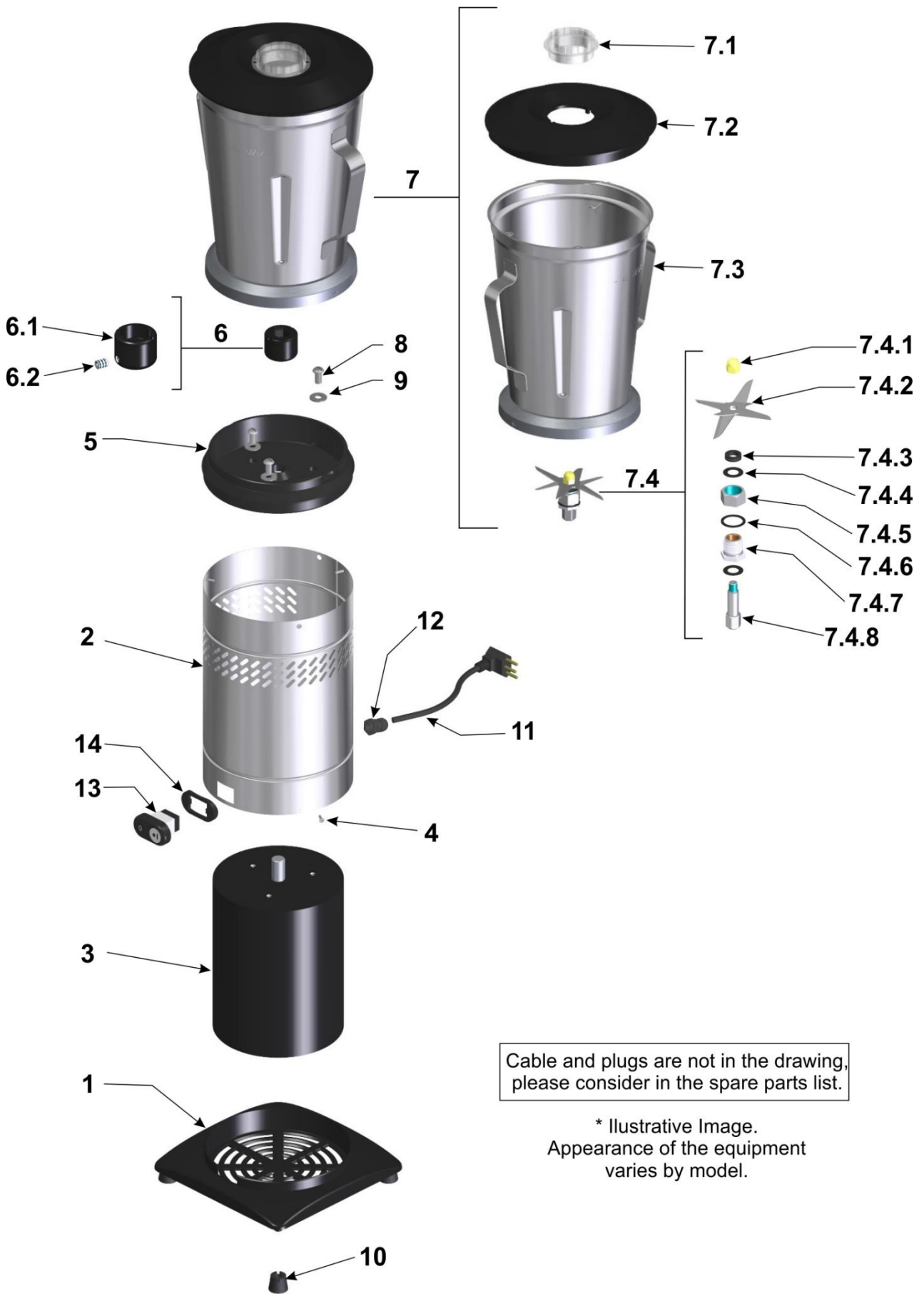

Cable and plugs are not in the drawing, please consider in the spare parts list.

\* Illustrative Image.  
Appearance of the equipment varies by model.

## Replacement parts

Position	Code	Description	Qty.	Application for Model
1	BAS045	Square Plastic Base	01	LQL.4/6/8/10
	ALF025	Square Aluminum Base	01	LQ4/6/8/10
2	GAB090	Cabinet	01	*
3	MTE260	Electric Motor 1/2 HP 60 Hz 127 V	01	LQ/LQL.4/6
	MTE261	Electric Motor 1/2 HP 60 Hz - 220 V	01	LQ/LQL.4/6
	MTE027	Electric Motor 1/2 HP 50 Hz - 220 V	01	LQ/LQL.4/6
	MTE258	Electric Motor 3/4 HP 60 Hz - 127 V	01	LQ/LQL.8/10
	MTE259	Electric Motor 3/4 HP 60 Hz - 220 V	01	LQ/LQL.8/10
	MTE087	Electric Motor 3/4 HP 50 Hz - 220 V	01	LQ/LQL.8/10
4	RBT002	Rivet	06	*
5	SUC017	Plastic Cup Holder	01	LQL.4/6/8/10
	ALF204	Aluminum Cup Holder	01	LQ4/6/8/10
6	CJT689	Full Coupling	01	*
6.1	ADA022	Coupling	01	*
6.2	PRN002	Screw	01	*
7	CJT1256	Full Stainless Steel Cup LQ/LQL.4	01	LQ/LQL.4
	CJT1258	Full Stainless Steel Cup LQ/LQL.6	01	LQ/LQL.6
	CJT1260	Full Stainless Steel Cup LQ/LQL.8	01	LQ/LQL.8
	CJT1262	Full Stainless Steel Cup LQ/LQL.10	01	LQ/LQL.10
7.1	TAP103	Overcap of the blenders	01	*
7.2	TAP157	Black Plastic Cover - LQ/LQL.4/6	01	LQ/LQL.4/6
	TAP158	Black Plastic Cover - LQ/LQL.10/8	01	LQ/LQL.10/8
7.3	COP173	Pointed Cup - LQ / LQL.4	01	LQ/LQL.4
	COP175	Dotted Cup - LQ / LQL.6	01	LQ/LQL.6
	COP177	Pointed Cup - LQ / LQL.8	01	LQ/LQL.8
	COP179	Pointed Cup - LQ / LQL.10	01	LQ/LQL.10
7.4	CJT690	Full Bearing of the Cup - LQ / LQL.4/6	01	LQ/LQL.4/6
	CJT850	Full Bearing of the Cup - LQ / LQL.8/10	01	LQ/LQL.8/10
7.4.1	POS015	Hexagonal Nut	01	*
7.4.2.	LMT002	Stainless Steel Blade	01	LQ/LQL.4/6
	LMT037	Stainless Steel Blade	01	LQ/LQL.10/8
7.4.3	VRG002	V'ring	01	*
7.4.4	ARE007	Celeron Graphite Washer Ø int.1/2" x Ø23 x 0,5 mm	02	*
7.4.5	POE010	Bearing Nut	01	*
7.4.6	ARE018	Celeron Graphite Washer Ø int. 22 x Ø28 x 1 mm	01	*
7.4.7	CJT140	Bearing with Bushing	01	*
7.4.8	EIX205	Axis of the Cup	01	*
8	PRS008	Hexagonal Screw	03	*
9	ARL042	Flat washer.	03	*
10	PEP018	Base Blender Foot	04	*
11	CBE020	Electrical Cable - Type 1	01	*
	CBE007	Electrical Cable - Type 2	01	*
	CBE272	Electrical Cable - Type 3	01	*
	CBE001	Electrical Cable - Type 4	01	*
	CBE175	Electrical Cable - Type 7	01	*
12	TCE073	Print cable	01	*
13	CHE064	On/Off Switch	01	*
14	BCH057	Switch Frame	01	*
15	TCE013	Female Terminal (Yellow)	01	*
16	TCE004	Terminal Fit (Blue)	04	*
17	CBE092	V/A Amendment Terminal (Earth)	01	*









**IMG BRASIL PRODUCT MANUFACTURER**

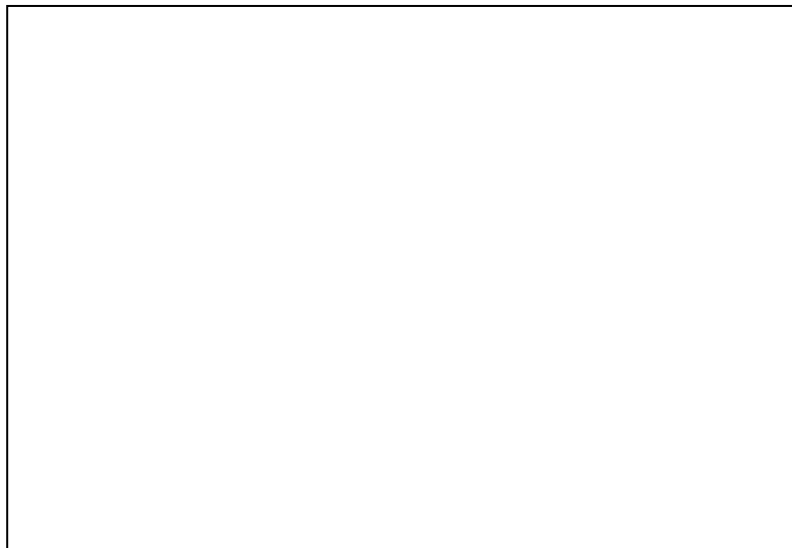

**IMG-BRASIL Gastronomy Machinery Industry Ltda.**

CNPJ 11.193.347/0001-14 - CREA 131726-3

Rod. Antônio Heil – KM 23 Nº 5825 – Limoeiro

CEP 88352-502 - Brusque – SC – Brazil

Phone/fax. +55 47 3251-5555 - Site: [www.metvisa.com.br](http://www.metvisa.com.br)

E-mail: [sac@metvisa.com.br](mailto:sac@metvisa.com.br) - [export@metvisa.com.br](mailto:export@metvisa.com.br) - [export2@metvisa.com.br](mailto:export2@metvisa.com.br)



Discover our complete  
line of products.