



INSTRUCTION MANUAL

Installation | Maintenance | Use | Safety

Food Processor Special

Model

MPAE



Image merely illustrates.

CONGRATULATIONS,

You have just purchased a IMG-BRASIL equipment, product of the highest quality, safety and efficiency.

Founded in 1989, IMG-BRASIL is a respected company as one of the best and most complete companies in the field of gastronomy equipment manufacturing.

Constant innovation and improvement of its products, using top-of-line raw materials, ensure superior products consumed in Brazil and in more than 25 countries worldwide.

THE RELIABILITY AND CERTAINTY OF A GOOD PRODUCT ARE IN THE NAME



IMPORTANT:

**PRODUCT FOR PROFESSIONAL USE. DO NOT USE BEFORE READING THE MANUAL CAREFULLY.
IN CASE OF QUESTIONS, PLEASE CONTACT US::**

IMG-BRASIL Gastronomy Machinery Industry Ltda.

CNPJ 11.193.347/0001-14 - CREA 131726-3

Road. Antônio Heil – KM 23 N° 5825 – Neighborhood: Limoeiro –

ZIP CODE 88352-502 - Brusque – SC – Brasil

Phone/fax. +55 47 3251-5555 - Site: www.metvisa.com.br

INDEX

1. Safety Information	4
1.1 General Warnings.....	4
2. Technical Characteristics	5
2.1 Main Components.....	5
2.2 Discs Included With The Equipment	6
2.2.1 Disc Characteristics.....	6
2.3 Technical Data.....	7
3. Installation	8
3.1 Equipment Layout.....	8
3.2 Electrical Connection	9
3.3 Safety Procedures and User Instruction.....	10
4. Equipment Use	11
4.1 Utility.....	11
4.2 Comandos	11
4.3 Operating Procedures.....	11
5. Cleaning and Maintenance	15
5.1 Cleaning Procedures and Products Used	15
5.2 Maintenance and Behavior in Case of Malfunctions.....	16
9. ANEXXES	17
Electrical Scheme.....	17
Exploded view drawing	18
Spare Parts	19
Spare Parts	20



ATTENTION!

The characteristics, pictures and figures presented in this manual should be considered for information. IMG BRASIL reserves the right to make such modifications as may be deemed necessary without prior notice.

1. Safety Information

1.1 General Warnings

- Cautions / precautions must be observed when installing, using, maintaining and discontinuing use of this equipment;
- Before carrying out any operation (assembly, use, maintenance and reuse after prolonged use of the equipment), read the manual carefully;
- The equipment must be used by trained personnel familiar with the use and safety regulations described in this manual;
- This equipment is not intended for use by persons (including children) with reduced physical, sensory or mental capacities, or people with lack of experience and knowledge, unless they have received instructions regarding the use of the equipment or are under the supervision of a person responsible for their safety.
- It is recommended that children be supervised to ensure that they are not playing with the equipment;
- In case of rotation of the personnel that will work with the equipment, the new operator must be educated about the standards and the operation of the same one;
- The operator must use the **Adequate PPE** (Personal Protective Equipment). As for example: use hair caps, preventing them from locking in the equipment's moving parts;
- The operator must always be aware of situations that can cause a risk of accidents and avoid them. For example: working on dirty floors where someone could slip and fall on the equipment;
- After reading and clarifying all doubts, this manual should be carefully stored in an easily accessible location, known to all persons who will operate the equipment and make it available to those who will carry out maintenance for any inquiries. Whenever any questions arise, be sure to check the manual. Do not operate the equipment in any way with doubts;
- In the installation, it is essential to make this manual available to the professionals who will do the same;
- Before starting cleaning and any type of maintenance, it is essential to disconnect the equipment from the electrical supply;
- Periodically check the condition of the cables and electrical parts;
- Do not turn the equipment on without the disc being correctly fitted and the disc case with the lid secured with the locker. Insert only specific products for which the equipment is intended and never put your hands, fingers or objects in the feeding nozzle, food outlet nozzle or moving parts with the equipment turned on, as this could cause an accident;
- Do not leave the equipment switched on unattended.



ATTENTION!

**Do not perform repairs on your own. Go to a service center authorized by the manufacturer.
Use only original parts in your equipment.**

2. Technical Characteristics

2.1 Main Components

For the equipment described in this manual, safety in use, cleaning, maintenance and maximum hygiene are guaranteed by the project and special design of all parts and also by using stainless steel and other materials suitable for contact with food.

The equipment was built with the following features:

- Lid, structure, inlet nozzle, outlet nozzle and handle are made of stainless steel, which has a corrosion resistance superior to that of other steels;
- Ejector disc made of high-resistance ABS plastic;
- Slicing discs, julienne discs, and fixed cube discs are made of ABS plastic, with stainless steel blades;
- Cutting disc (cube) in aluminum with stainless steel blades;
- Shredding and grating discs with ABS plastic base and stainless steel coated surface;
- Pusher made of non-toxic PS (polystyrene) plastic.

See below for the main components of the equipment:

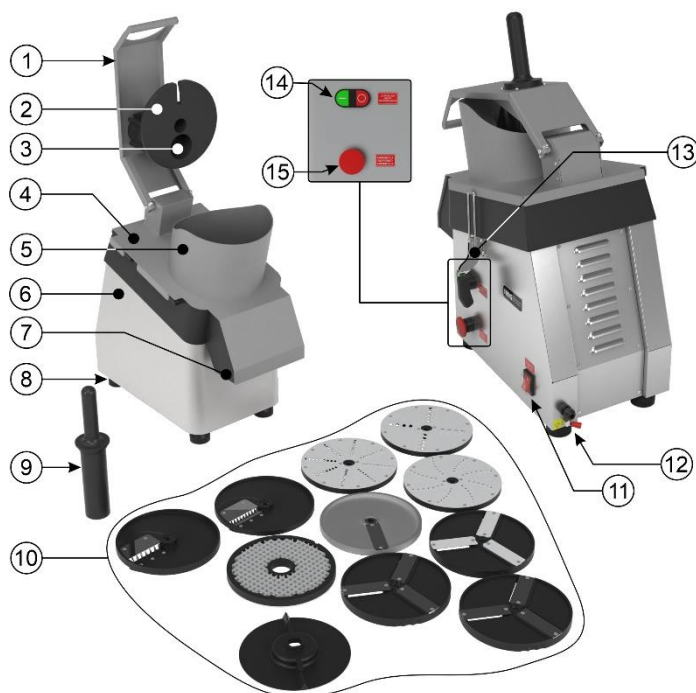

Description:

1. Handle;
2. Pusher;
3. Small inlet nozzle;
4. Lid;
5. Large inlet nozzle;
6. Structure;
7. Outlet Nozzle;
8. Feet;
9. Pusher;
10. Discs;
11. General Switch;
12. Ground connection;
13. Locker;
14. On/off Switch;
15. Emergency button.

Note: For exploded view with spare parts list, see the annexes.

2.2 Discs Included With The Equipment

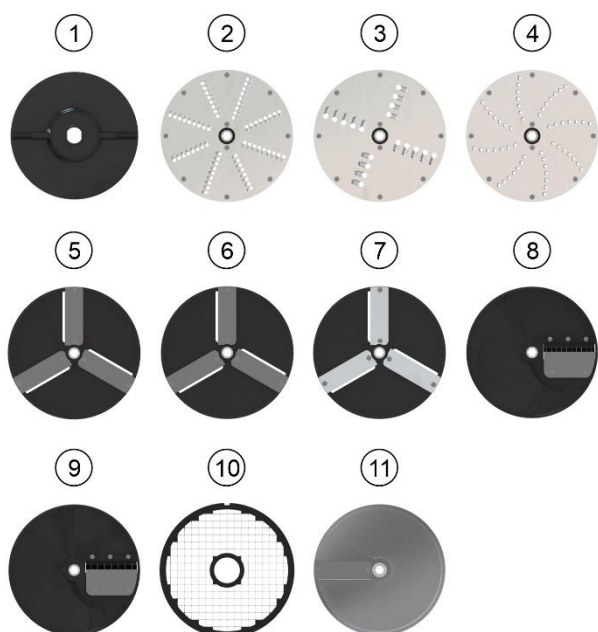

Position	Code	Description
1	DIS078	Ejector Disc
2	CJT1383	Shredding Disc, 5 mm
3	CJT1384	Shredding Disc, 8 mm
4	CJT1382	Grating Disc
5	CJT1379	Slicing Disc, 1,5 mm
6	CJT1380	Slicing Disc, 3 mm
7	CJT1381	Wave Slicing Disc, 3 mm
8	CJT1526	Julienne Disc 10x10
9	CJT1536	Julienne Disc 7x7
10	DIS084	Fixed Cube Disc
11	CJT1387	Cutting Disc (Cube), 10 mm

2.2.1 Disc Characteristics

The table below presents suggested types of cuts for certain products. The processing result may vary depending on the state, type, and quality of the product used.

Food	Slicing Disc	Disco Fatiador Ondulado	Julienne Disc	Shredding Disc	Grating Disc	Cube Disc
Zucchini	1,5/3 mm	3 mm	10x10 / 7x7 mm	5/8 mm		
Potato	1,5/3 mm	3 mm	10x10 / 7x7 mm	5/8 mm		Cutting 10mm + Cube 10x10mm
Beet	1,5/3 mm		10x10 / 7x7 mm	5/8 mm		Cutting 10mm + Cube 10x10mm
Onion*	1,5/3 mm			5 mm		Cutting 10mm + Cube 10x10mm
Carrot*	1,5 mm	3 mm	10x10 / 7x7 mm	5/8 mm		Cutting 10mm + Cube 10x10mm
Chocolate					X	
Cabbage*	1,5/3 mm					
Mushroom	1,5/3 mm					
Apple	1,5/3 mm					
Cucumber*	1,5/3 mm	3 mm		5 mm		
Bell Pepper	1,5/3 mm	3 mm				Cutting 10mm + Cube 10x10mm
Cheese				5/8 mm	X	
Parmesan					X	
Radish	1,5/3 mm	3 mm		5/8 mm		
Repolho	1,5/3 mm			5/8 mm		
Tomate	1,5/3 mm					Cutting 10mm + Cube 10x10mm

*For these products it is only recommended to use the small nozzle. The use of large nozzle will result in less quality in the product process.



ATTENTION!

Discs (especially the cube disc) should not be used for processing the following foods:

- Meats (steak, chicken, bacon, and sausages);
- Fibrous foods, such as ginger;
- Highly rigid vegetables, such as kabocha squash, cassava (yuca), and sweet potato.

Using the equipment with non-recommended foods may result in irregular cuts, equipment jamming, and risk of damage, as well as compromising operator safety.

2.3 Technical Data

Model	Description	Nominal Measures (mm) LxHxW	Net Weight (kg)*	Voltage (V)	Nominal Rate (A)	Number of Discs Included**	Capacidade (kg/h)***
MPAE220M50S1	Compact Food Processor	293x682x586	23,8	220	4,2	7	180 to 250
MPAE220M50S2				220	4,2		
MPAE220M50S7				220	4,2		
MPAE110M60S4				110	10,6		

* Weight considered without discs and pusher.

** Number of discs included considered without ejector disc.

*** May vary due to the user's work speed and the disc model used and the processed product.

Equipment dimensions (in mm):

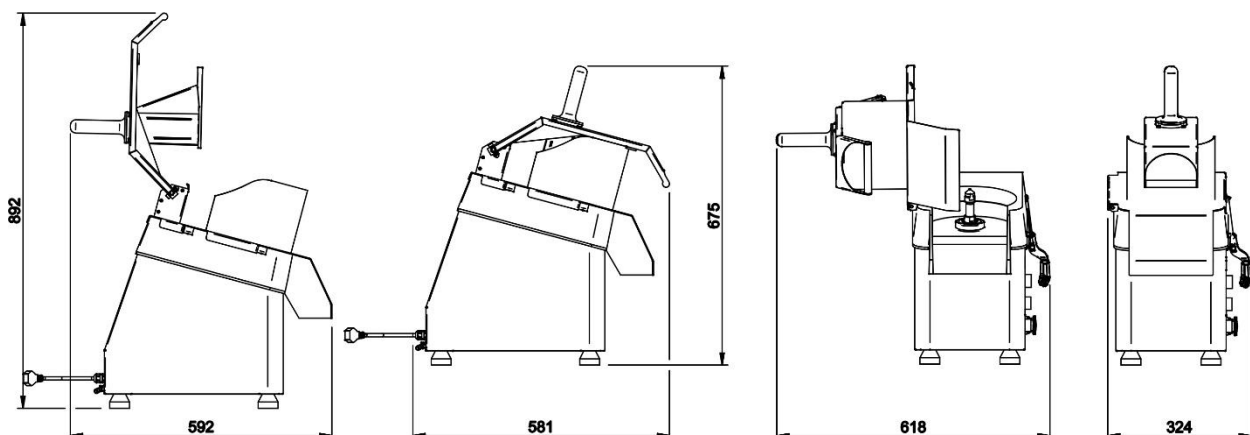



ATTENTION!

Characteristics like: model, serial number and voltage of the equipment are provided on the label (figure below). Before installation, check that the power supply voltage of the equipment corresponds to that of the mains.



3. Installation

3.1 Equipment Layout

Connection to the mains and layout must be carried out by a qualified professional. Check that the voltage of the equipment matches that of the mains.

During installation, it is essential to make this manual available to the professionals who will carry out the installation.

To ensure correct operation and safety, place the equipment in a well-ventilated area and on a support surface that is large enough, well leveled, dry and stable, away from heat sources and water taps, and at a medium height. of 80 cm. Install your equipment leaving a distance of at least **20 cm (A)** around it and **1.0 m (B)** in height, so that you have enough space for inspection, maintenance, cleaning and use.

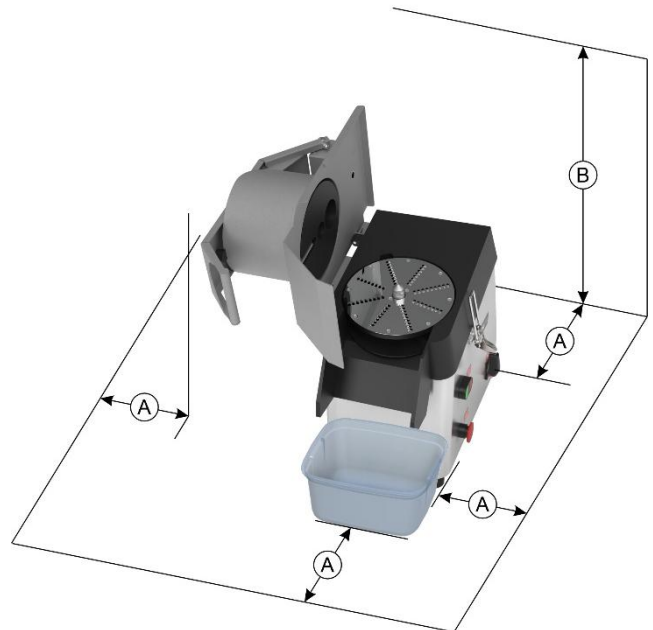

* The equipment does not include a container.



ATTENTION!

The installation and the place where the equipment will be placed must be in accordance with the Rules for the Prevention of Risks at Work and Safety at Work in Machines and Equipment.

The manufacturer does not take responsibility for possible direct or indirect damage caused by failure to comply with said standards and other instructions presented in this manual.

3.2 Electrical Connection

The equipment comes with a power cord for connection to an electrical outlet. If the power cord is damaged, it must be replaced with a new one. Replacement should be carried out by the manufacturer, authorized agent, or qualified person to avoid risks.

The equipment also includes an equipotential grounding terminal, located on the back of the base.

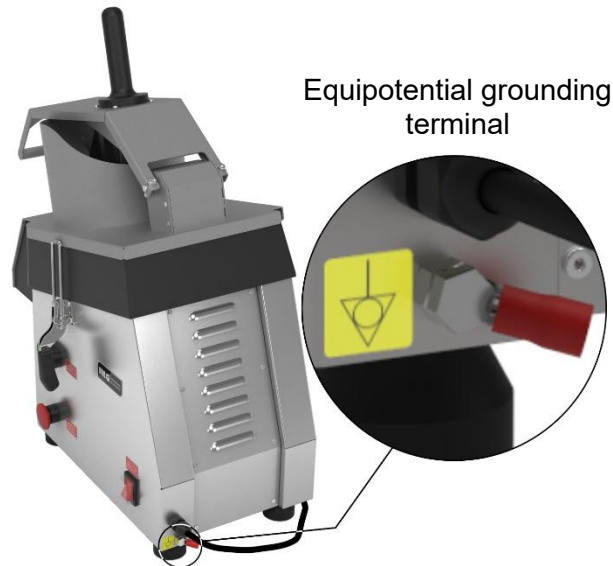

The terminal connector identified in the figure above provides additional protection to the grounding provided in the electrical grid. It must be connected to a grounding terminal block, independent of the electrical grid connection. Other stationary products with accessible metal parts must also be connected to this block, as well as the service bench itself, if made of metal. This ensures that all these products are under the same electrical potential, preventing unwanted leakage currents.

The equipment is monovolt, that is, it operates at 110 V or 220 V. If a voltage change is necessary, contact the manufacturer or authorized dealer.



ATTENTION!

Before turning on your equipment, always check that the power supply voltage matches the equipment's voltage.

The power supply voltage for this equipment is 110 V or 220 V (60 Hz), as shown on the voltage label affixed to the power cord or as indicated on the rating plate on the back of the equipment (see the illustration of this label in section 2.2 of this manual).

Make sure that the voltage of the electrical network where the equipment will be installed is compatible with the voltage indicated on these labels.

For further details on the rest of the electrical part of the equipment, consult the electrical diagram in the manual's annexes.

IMPORTANT

The manufacturer does not take responsibility for possible direct or indirect damage caused by failure to comply with said standards and other instructions presented in this manual.

3.3 Safety Procedures and User Instruction

The professional who sells the equipment must instruct the user on the correct functioning of the equipment and must hand over this instruction manual.

The user must be informed of the necessary safety measures and must respect them, as well as all measures described in this manual.

Your equipment has mechanical safety and a safety system that prevents operation if the lid is open or the pusher is raised. Removing or tampering with these safety components can cause serious injuries to the operator's upper limbs.



ATTENTION!

Before operating your equipment, check the direction of rotation of the disc. To do this, make sure the lid is closed and locked with the locker and the handle down. The equipment has a safety system that will prevent it from operating if the lid is open.

Turn on the equipment and check, through the small feeding nozzle, if the disc is rotating counterclockwise, as shown in the figure below.

If the disc is rotating clockwise, consult the electrical diagram (Item 9) or contact the nearest authorized technical assistance

With the lid locked and the handle lowered, remove socket "A" and view the direction of rotation of the disc (counterclockwise rotation "C") through the opening located in the pusher "B".

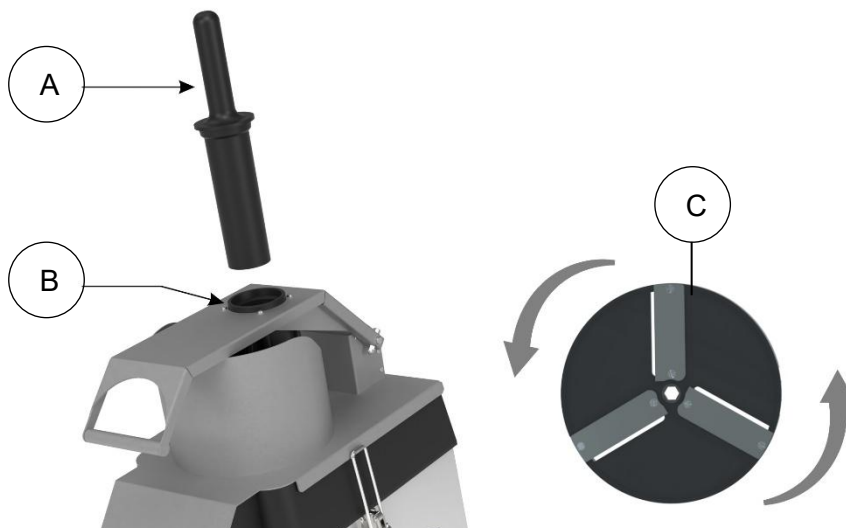

4. Equipment Use

4.1 Utility

This equipment is intended for slicing, shredding and grating food products.

4.2 Comandos

The equipment consists of a general switch, an emergency button, and an on/off switch which, when viewed from the front of the outlet nozzle, are located on the right side of the equipment.



Description:

- A. On/Off switch;
- B. Emergency Button;
- C. General Switch (Interrupter).

View the description of each command below:

A - On/Off switch – used to turn the equipment on and off. In position “1” it turns on, in position “0” it turns off.

B. Emergency Button – must be used in case of necessity to stop the equipment due to some emergency. To arm the button you just need to push and to disarm, turn the button on clockwise (as indicated by the arrows on the button).

C. General Switch (Interrupter) – switch used to in a safety way turn on and turn off the energy from the electrical mains to the equipment. In the position “1” turns on, “0” turns off the energy to the equipment.

4.3 Operating Procedures

Before operating your equipment, clean the components that will come into contact with food (pusher, disc, etc.), to do so, make sure that the equipment is disconnected from the electrical network, only then dismantle it. Follow the cleaning instructions in item 5 of this manual.

Check the disassembly and assembly processes described below

• **Disc assembly:**



ATTENTION!

The ejector disc should always be the first one to be assembled, regardless of the type of disc that will be used next. It is essential for the ejection of the processed product and must be used in all assembly configurations.

- ① Before start the disassembly disconnect the equipment from the electrical network.
- ② Remove the pusher "A".
- ③ Raise the lock "B" to unlock the lid and carefully open "C".

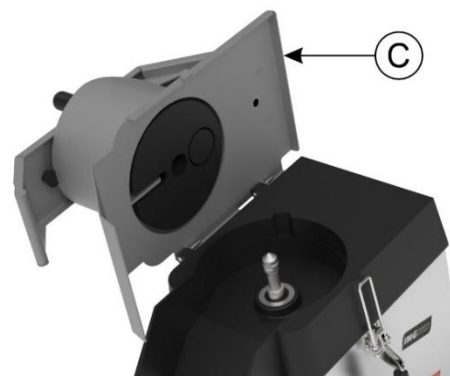
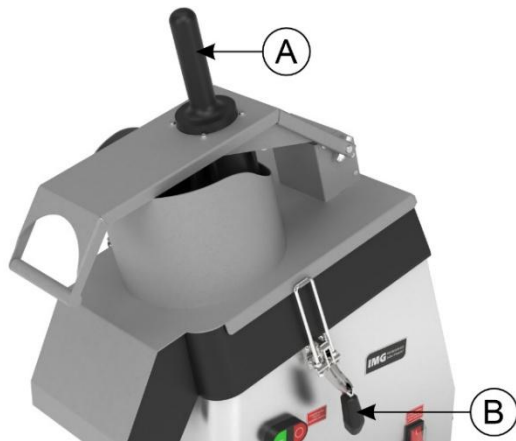

- ④ Fit the ejector disc "E" onto the equipment shaft "D", pressing down lightly until it fits correctly into the grooves (facets) of the shaft.

IMPORTANT

The ejector disc should always be the first one to be assembled, regardless of the type of disc that will be used next.

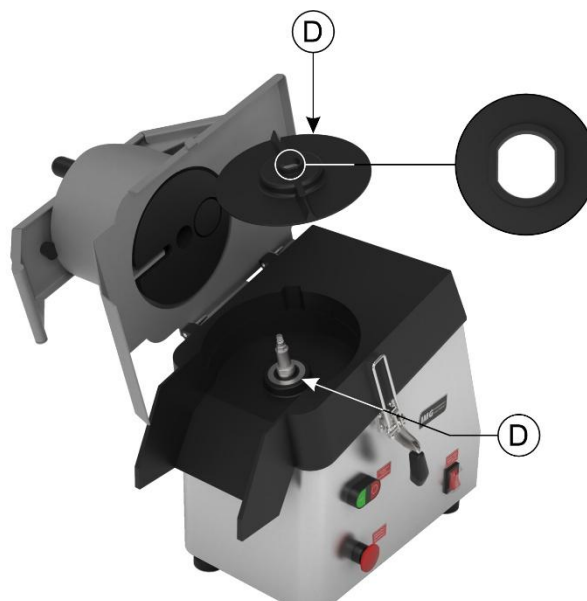

Check the disk models in item 2.1 (Main Components), select and install the working disks as needed.

Case 1 – Using only one disc (slicer, grater, or shredder):

After installing the ejector disc "E," choose the desired disc "F" and fit it onto the shaft, turning it slightly counterclockwise until it feels firm and correctly fitted. Finally, screw the nut "G" clockwise to lock the discs in position.

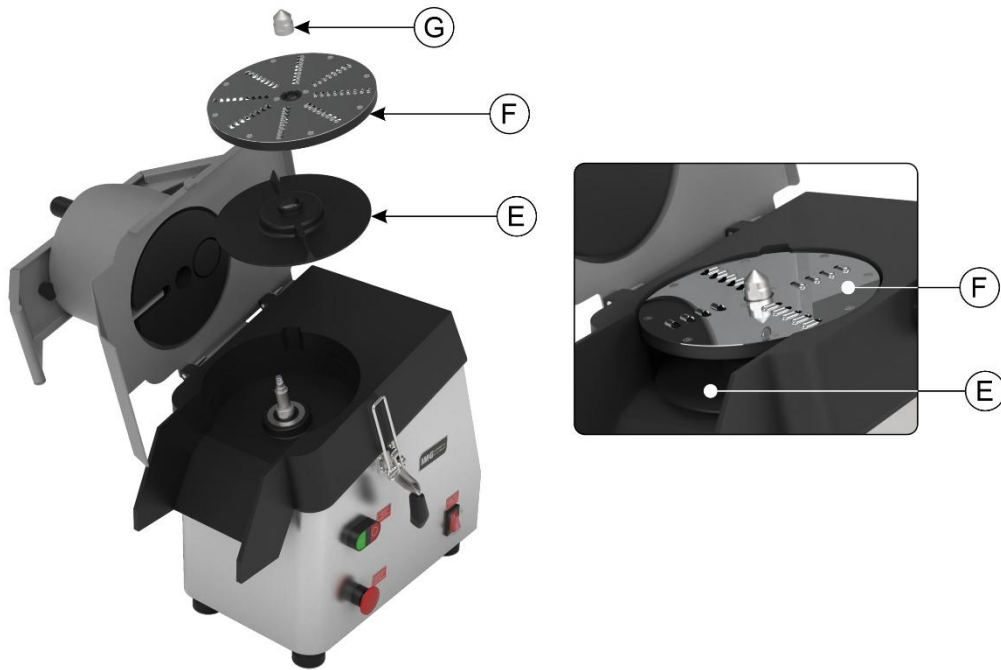

Case 2 – Using two discs (fixed disc + cutting disc):

After installing the ejector disc "E," first position the fixed disc (cube) "I" in the machine's internal fit. Next, fit the cutting disc "H" onto the shaft, turning it slightly counterclockwise to ensure proper fit. Finally, screw the nut "G" clockwise to lock the discs in place.

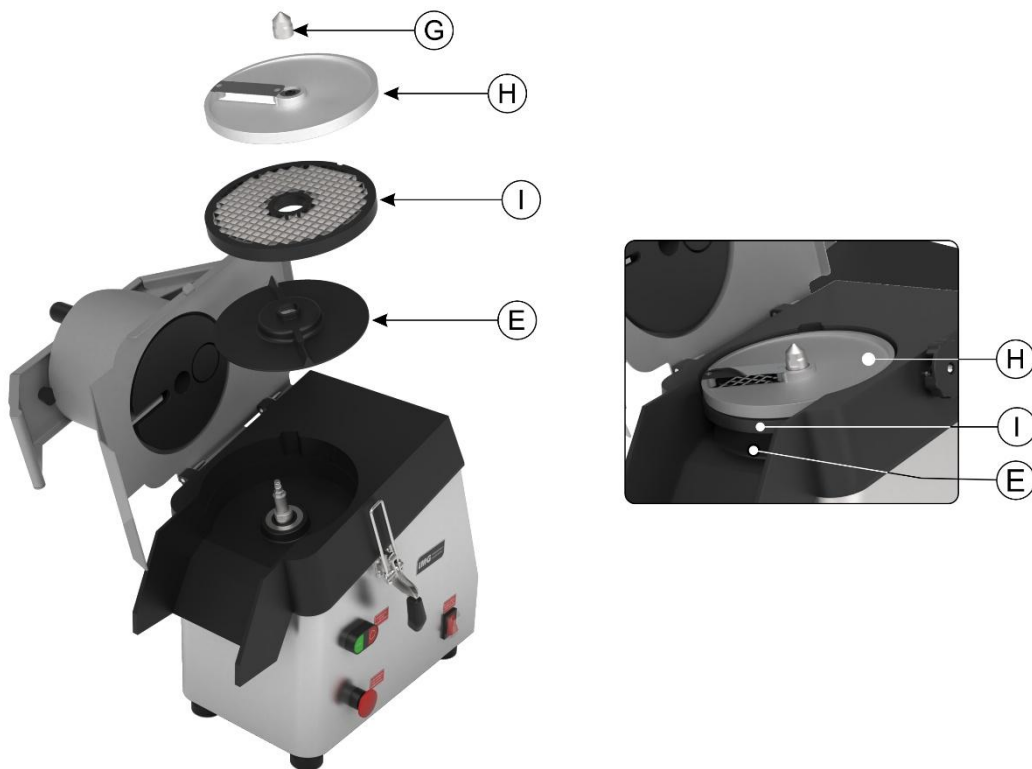



ATTENTION!

Before beginning the assembly or disassembly process, disconnect the equipment from the electrical outlet.

Never turn on the equipment with the disc out of position, as this can cause accidents.

Handle the discs carefully as they contain blades.

Always check that the discs are fully seated. Incorrect fitting can compromise operator safety and equipment operation.

Never turn on the equipment with the disc out of position, as this can cause accidents.

- ⑤ After correctly fitting the discs, lower the lid and turn the locker (counterclockwise) until it is fully locked. Make sure it is securely fastened before turning on the equipment.

• Disc disassembly:

The disassembly procedure is the reverse of the assembly procedure.

• **Operation:** The equipment can only be operated after checking that the disc is firmly in place and the lid is locked with the locker, and that the voltage of the equipment matches that of the electrical power supply.

After checking these items, follow the equipment operation processes below:

- Connect the power cable to the electrical network;
- Place a bucket* to store the processed food below the outlet.;
Note: *bucket not included with the equipment.
- Turn on the general switch (interrupter) of the equipment, activate the on/off switch in position “1” (on);
- For long and cylindrical foods, keep the handle down, insert the foods through the small nozzle and push them against the disc with the pusher. For larger foods, lift the handle, insert the foods into the larger nozzle and push with the handle;
- After finishing the process, turn off the equipment by pressing the on/off switch in position “0” (off).



ATTENTION!

If you notice that the equipment cannot process the food or that it stops processing, reduce the quantity or pre-cut the food before inserting it into the feeding nozzle. Excessive pressure exerted with the handle or pusher to press the food against the disc can also impair the speed and performance of the motor, disc, and the life of the equipment



ATTENTION!

Do not try to open the lid or remove the disc with the equipment turned on, nor should you put your fingers, hands or objects (such as spoons and knives) inside the feeding nozzle, as this could cause accidents.

Always use the handle or pusher to process food, never use your hands to push food during operation.

In case of any irregularity, contact the nearest authorized technical assistance.

IMPORTANT

The operator must use the appropriate PPE (personal protection equipment). For example: wearing a hair cap to prevent it from tangling in the moving parts of the equipment and appropriate gloves that, in addition to ensuring hygiene in food handling, protect the operator during the process.

5. Cleaning and Maintenance

5.1 Cleaning Procedures and Products Used

Your equipment was built with first-line materials, so use it properly and you will obtain great satisfaction. Always keep your equipment clean and well-cared for, which will make it much more durable.

The equipment must be cleaned daily to ensure it works properly and has a longer service life.



ATTENTION!

Before carrying out maintenance or cleaning, make sure that the on/off switch is in position “0” (off) and that the plug is disconnected from the mains.



ATTENTION!

Do not use water jet or steam cleaner to clean the equipment.

IMPORTANTE

This equipment is not intended to be immersed in water for cleaning. Follow the instructions below to find out which parts can be immersed and what special care should be taken with the other parts.

The detachable parts (discs and pusher) must be removed from the equipment (according to the instructions in item 4.3) and washed with warm water and neutral detergent. Clean the corners well, eliminating food residues.

The rest of the equipment should be cleaned as often as possible to prevent food residues from drying out and sticking to the parts. For cleaning, dilute soap or neutral detergent in warm water and apply with a soft cloth. With a cloth moistened with water, rinse and then dry the parts with a dry and soft cloth.

Never use abrasive products or sponges and substances that contain acids or chlorine to clean the metal parts, as they can scratch or damage the surface of the parts causing corrosion points. Do not pour water over the motor and electrical parts for cleaning, otherwise, when turning it on, it may cause an electric shock or even burn the equipment.



ATTENTION!

Be careful when cleaning the discs, they are extremely sharp. Handle with care, otherwise it could cause accidents. The same attention is given to any other sharp component of the equipment.

IMPORTANT

The manufacturer does not take responsibility for possible direct or indirect damage caused by non-compliance with the rules and instructions presented in this manual.



ATTENTION!

It is extremely important that the products used in cleaning ensure maximum cleanliness and are not toxic.

5.2 Maintenance and Behavior in Case of Malfunctions

The operator should be instructed to perform routine inspections, making minor adjustments, cleaning, and observing any signs of potential failures. Examples include: checking for unusual noises; loss of equipment power; failure of the equipment to perform its intended purpose; among others. Actions such as these are essential to ensure a longer equipment life.



ATTENTION!

When carrying out maintenance (even minor adjustments), always disconnect the equipment from the electrical network.

It is recommended to perform preventive maintenance every 6 months, checking and adjusting clearances, cleaning internal parts, lubricating, etc. When broken or malfunctioning parts are detected, replace them, always using original parts.

Performing preventive maintenance eliminates the inconvenience of having the equipment out of service when it is most needed, reduces maintenance costs, and decreases the risk of accidents.



ATTENTION!

Preventative maintenance requires a trained professional.

Make sure the equipment is unplugged from the power outlet.

Whenever any safety-related item is removed from the equipment (such as during maintenance), replace it and confirm that it is performing its function correctly.

If you detect any malfunction or non-compliance, send your equipment to the nearest technical support center. See the list of technical support centers in the folder provided with your equipment or visit our website: www.metvisa.com.br

9. ANEXXES

Electrical Scheme

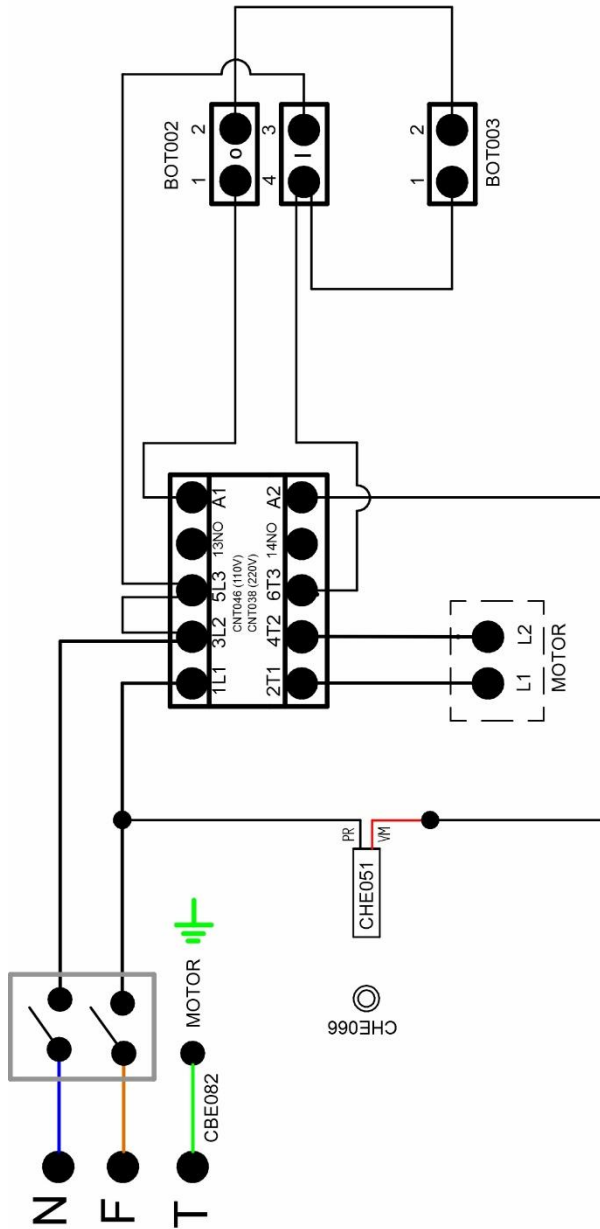

LEGENDA - SUBTÍTULO - SUBTITLE (PT - ESP - ENG)	
T	Terra - Tierra - Ground
N	Neutro - Neutral
F	Fase - Phase
PR	Preto - Negro - Black
VM	Vermelho - Rojo - Red

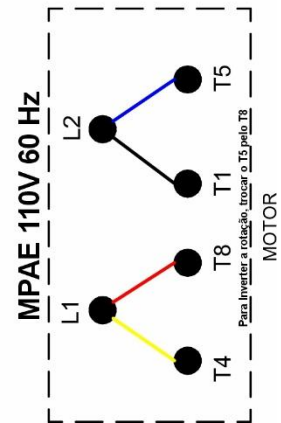
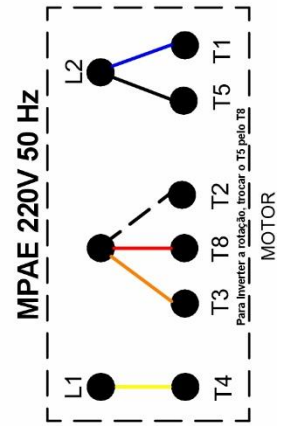

Spare Parts

Position	Code	Description	Qty.
1	SQT026	Socket	1
2	PCC015	Machine Screw CL Philips Stainless Steel	4
3	PRT032	Allen Screw Stainless Steel	2
4	POC006	Hats Stainless Steel Nut	2
5	CJT1448	Sensor Closure with Stop	1
6	RBT001	Rivet	16
7	PRR012	Round Machine Screw Stainless Steel	2
8	CHE177	Magnetic Actuator	1
9	PRN019	Stainless Steel Screw	1
10	APE029	Retaining Ring	2
11	EIX343	Lever Shaft	1
12	PEP010	Foot	1
13	CRC1671	Rear Closure	1
14	CBE020	Electrical Cable - Type 1	1
	CBE007	Electrical Cable - Type 5	1
	CBE001	Electrical Cable - Type 4	1
	CBE175	Electrical Cable - Type 7	1
15	TCE073	Cable Gland	1
16	CJT704	Assembled Equipotential Terminal	1
17	CHE087	Main Switch	1
18	BOT002	Double Button	1
19	BOT003	Emergency Button	1
20	PRS010	Hex Head Zinc Screw	4
21	ARL004	Plastic Washer Zinc Screw	14
22	PRS062	Hex Head Zinc Screw	12
23	PRN001	Allen Screw	3
24	ALV012	Pusher Lever	1
25	EPR033	Pusher	1
26	CJT1548	Welded Cover	1
27	CJT1553	Housing with Threaded Insert	1
28	CJT1546	Welded Cabinet - Single Safety	1
29	RBT020	Rivet	4
30	CRC1675	Motor Support	1
31	PMT004	Motor Pulley	1
32	MTE230	Electric Motor 1/2 hp 4P 60 Hz 127V	1
32	MTE038	Electric Motor 1/2 hp - 220V - 50Hz	1
33	CRC1673	Bottom Closure	1
34	PEP028	Foot	4
35	CRC1674	Plate Support	1
36	TRS056	Rail for Electrical Box	1
37	PRN010	Stainless Steel Screw	2
38	EIX341	Cover Shaft	2
39	CJE237	Electrical Assembly - MPAE 110V	1
	CJE238	Electrical Assembly - MPAE 220V	1

Spare Parts

Position	Code	Description	Qty.
40	FCH027	Tension Clamp	1
41	PRT071	Stainless Steel Allen Screw	4
42	RET028	Retainer	1
43	POS130	Hex Nut Stainless steel	4
44	EIX342	Shaft with hexagonal fitting	1
45	APE004	Retaining ring	1
46	ROL050	6004 2RS bearing	2
47	PRL004	Bearing clamp	1
48	CHE074	Dual channel safety sensor 200 mm	1
49	CRC1676	Magnetic sensor lock	1
50	PCC013	Stainless steel screw	2
51	POL037	Driven plastic pulley	1
52	COR049	Belt	2
53	TRV043	Disc lock	1
54	CRC1732	Sensor actuation plate	1
55	----	Discs	----
55.01	DIS078	Ejector Disc	1
55.02	CJT1379	1.5mm Slicing Disc	1
55.03	CJT1380	3.0mm Slicing Disc	1
55.04	CJT1381	3.0mm Wavy Slicing Disc	1
55.05	CJT1382	Fine Grating Disc	1
55.06	CJT1383	5.0mm Shredding Disc	1
55.07	CJT1384	8.0mm Shredding Disc	1
55.08	CJT1536	7x7mm Julienne Disc	1
55.09	CJT1526	10x10mm Julienne Disc	1
55.10	DIS084	Fixed Dicing Disc	1
55.11	CJT1387	10mm Dicing Disc	1
56	----	Cables and Connectors	----
56.01	TCE004	Blue Female Insulated Terminal	2
56.02	TCE013	Yellow Female Insulated Terminal	1
56.03	TCE033	Orange Threaded Connector with Metal Spring	2



IMG-BRASIL Gastronomy Machinery Industry Ltda.

CNPJ 11.193.347/0001-14 - CREA 131726-3

Road. Antônio Heil – KM 23 N° 5825 – Neighborhood: Limoeiro –

ZIP CODE 88352-502 - Brusque – SC – Brasil

Phone/fax. +55 47 3251-5555 - Site: www.metvisa.com.br



Know our complete
line of products.